

CONTENT

| | |
|--|--------------|
| Safety Precautions | P. 2 |
| Control Panel & Terminals | P. 6 |
| Preparations | P. 8 |
| * Setting Up | P. 8 |
| * Connections | P. 9 |
| Earphone and Audio output | P. 9 |
| MIDI input/output | P. 9 |
| Listening to the Demo Songs | P. 10 |
| Basic Operation | P. 12 |
| Playing the Piano | P. 14 |
| * Selecting and Playing a Voice | P. 14 |
| Percussion | P. 15 |
| * Keyboard Split Mode | P. 16 |
| Changing the Split Voice and Relative Parameters | P. 17 |
| * Touch Response | P. 18 |
| * Dual Voice | P. 18 |
| Selecting the Relative Parameters of Dual | P. 19 |
| * Harmony/Echo | P. 20 |
| Selecting the Harmony / Echo | P. 20 |
| * Sustain | P. 21 |
| * Mute | P. 21 |
| * Transpose | P. 22 |
| * Pitch Bend | P. 22 |
| Number Effect | P. 23 |
| * Using Number Effect | P. 23 |
| * Changing the Reverb Effect | P. 23 |
| Selecting the Reverb Style | P. 23 |
| Setting the Reverb Return Level | P. 24 |
| * Changing Chorus Effect | P. 25 |
| Selecting the Chorus Style | P. 25 |
| Setting the Chorus Return Level | P. 26 |
| * Selecting 3D Effect | P. 26 |
| Using Auto Accompaniment | P. 27 |
| * Selecting Accompaniment Mode | P. 27 |
| * Selecting the Style | P. 29 |
| * Setting the Tempo | P. 29 |
| * Start the Accompaniment | P. 30 |
| * Accompaniment Track Control | P. 33 |
| * Changing the Split Point of the Accompaniment Track | P. 35 |
| Registration Memory | P. 36 |
| * Register Panel Setting | P. 36 |
| * Recalling the Registered Panel Setting | P. 37 |
| * Accompaniment Freeze Function | P. 37 |
| Song Recording | P. 38 |
| * Melody Track Recording | P. 38 |
| * Accompaniment Track Recording | P. 40 |
| * Melody & ACMP Tracks Playback | P. 42 |
| Practice Function | P. 43 |
| * Minus Channel Mode | P. 44 |
| * Repeated Playback | P. 44 |
| Whole Function | P. 45 |
| * Common Functions | P. 46 |
| Keyboard Volume | P. 46 |
| Octave | P. 46 |
| Reverb Level | P. 46 |
| Chorus Level | P. 47 |
| Pan | P. 47 |
| Voice Set | P. 47 |
| Accompaniment Volume | P. 47 |
| Touch Sensitivity | P. 48 |
| Minus Channel | P. 48 |
| Metronome | P. 48 |
| Pitch | P. 48 |
| * MIDI Functions | P. 49 |
| Send & Receive | P. 49 |
| Keyboard Output | P. 49 |
| Appendix | P. 50 |
| * Voice List | P. 50 |
| * Rhythm List | P. 52 |
| * Drum Set Table | P. 53 |
| * Technique Specifications | P. 55 |

SAFETY PRECAUTIONS...

■ Symbols

Various symbols are used in this user's manual guide and on the product itself to ensure that the product is used safely and Correctly, and to prevent injury to the user and other person as well as damage to property. Those symbols along with their Meanings are shown below.

■ **WARNING!**

This indication stipulates matters that have the risk of causing death or serious injury if the product is operated incorrectly while ignoring this indication.

■ **CAUTION!**

This indication stipulates matters that have the risk of causing injury as well as matters for which there is the likelihood of occurrence of physical damage only if the product is operated incorrectly while ignoring this indication.

■ Symbol Examples

 This triangle symbol means that the user should be careful. (The example at left indicates electrical shock caution.)

 This circle with a line through it means that the indicated action must not be performed. Indications within or nearby this symbol are specifically prohibited. (The example at left indicates that disassembly is prohibited.)

 The black dot means that the indicated action must be performed. Indications within this symbol are actions that are specifically instructed to be performed. (The example at left indicates that the power plug must be unplugged from the electrical socket.)

—————  ! WARNING —————

■ Please use caution regarding the handling of the AC adaptor.

- Do not use a voltage other than the indicated power supply voltage. Use of a voltage other than that indicated may cause fire or electrical shock.
- If the power cord should become damaged (expose wired, disconnection, etc.), purchase a new AC adaptor. Use of a damaged power cord may cause fire or electrical shock.
- Do not cut or damage the power cord. Also do not place heavy objects on top of it or subject it to excessive heat.

Damage to the power cord may cause fire or electrical shock.

- Do not attempt to shape the power cord or subject it to excessive bending, twisting or pulling. This may cause fire or electrical shock.

- Please use the adaptor specified for this instrument. Use if another adaptor may cause fire, electrical shock, or malfunction.

- **Do not locate the instrument or its stand on an uneven or unstable surface.**

- * Locating the instrument or its stand on an uneven or unstable surface can cause it to fall, creating the danger of personal injury.

- **Do not place containers containing water or other liquids on the instrument.**

- Do not place the following objects on the instrument. Placing such objects on the instrument may cause fire or electrical shock if they fall and get inside the instrument.



- Containers filled with water or other liquids (including vases, potted plants, cups, cosmetics and medicines)

- Small metal objects (including hairpins, sewing needles and coins)

- Flammable objects

In the event a foreign object should happen to get inside the instrument, please take the following actions:

1. Turn power off.



2. Unplug the AC adaptor from the wall outlet.

3. If there are any batteries loaded in the keyboard, remove them.

- * Do not touch the batteries directly with your hands when removing them. They may be hot or battery fluid may be leaking from them.

4. Consult with the dealer where you purchase the keyboard or with an authorized PRELUDE service provider.

- **Do not disassemble or modify the instrument.**



- Never attempt to take apart or modify the instrument, its accessories, or separately sold options. Doing so may cause fire, electrical shock or malfunction. Consult your dealer concerning all inspection, adjustment or repair of internal components.

- **Do not use if there is an abnormality or malfunction.**



- * Do not use the instrument if there appear to be abnormalities such as the presence of smoke or abnormal odor. Also do not use the instrument if there appear to be malfunctions such as the power not coming on or sound not being produced. Use under such conditions may cause fire or electrical shock. In such cases, take the following actions immediately. Never attempt to repair the instrument yourself.

1. Turn power off.



2. Unplug the AC adaptor from the wall outlet.

3. If there are any batteries loaded in the keyboard, remove them.

- * Do not touch the batteries directly with your hands when removing them. They may be hot or battery fluid may be leaking from them.

4. Consult with the dealer where you purchased the keyboard or with an authorized PRELUDE service provider.

- **When the instrument has been dropped:**



- * In the case the instrument has been dropped or damaged, take the following actions.

Continued use may cause fire or electrical shock.

1. Turn power off.



2. Unplug the AC adaptor from the wall outlet.

3. If there are any batteries loaded in the keyboard, remove them.

- * Do not touch the batteries directly with your hands when removing them. They may be hot or battery fluid may be leaking from them.



4. Consult with the dealer where you purchased the keyboard or with an authorized PRELUDE service provider.

■ Be careful of the bags around children.

- *. Never allow anyone to place the plastic bags of the instrument, its accessories, and its separately sold options over their heads. Doing so may cause suffocation. Particular caution is required in homes with small children.

CAUTION

■ AC Adaptor

-  *. Do not locate the power cord in close proximity to heaters or other heating appliances. This may cause the cord to melt leading to possible fire or electrical shock.
-  *. When unplugging the AC adaptor from an electrical outlet, always make sure to pull on the adaptor itself and not the cord. Pulling excessively on the cord may cause it to be damaged or break leading to possible fire or electrical shock.
-  *. Do not touch the AC adaptor with wet hands when it is plugged in. This may cause electrical shock.
- *. When not using the instrument for an extended period such as when traveling, always make sure to unplug the AC adaptor from the electrical outlet for safety reasons.
- *. After use turn off the power switch of the instrument and unplug the AC adaptor from the electrical outlet.

■ Batteries

- *. Improper battery use may cause batteries to rupture and leak. This may cause injury, malfunction of the instrument or discoloration of furniture and other articles that come into contact with battery fluid. Take care to observe the followings.
 - *. Install batteries so their polarity (+/-) matches that indicated on the instrument.
 - *. For safety and to prevent possible leakage of battery fluid, always make sure to
- remove batteries from the instrument when you do not plan to use it for a long time.
 - *. Always make sure that the batteries making up a set are all of the same type.
 - *. Never combine the new batteries with old ones.
 - *. Never dispose of batteries by incinerating them. Never short or disassemble batteries, and do not expose them to excessive heat.
 - *. Replace dead batteries as soon as possible.
 - *. Never attempt to recharge batteries.

■ Transport

-  *. When transporting the instrument, always make sure to unplug the AC adaptor from the electrical outlet and confirm that all other external connections have been disconnected. Only then should the instrument be transported. If the above is not done, the cord may be damaged leading to possible fire or electrical shock.

■ Care

-  *. Whenever caring, make sure to first unplug the ac adaptor from the electrical outlet. Also remove the instrument's batteries if battery power is being used.

■ Location

-  *. Never locate the instrument in areas subject to high humidity or heavy accumulation of dust. Doing so may cause fire or electrical shock.
- *. Never locate the instrument in areas subject to grease splatters or steam, such as in a kitchen or near a humidifier. Doing so may cause fire or electric shock.

■ Don not place keyboard on lacquered furniture.

*. The instrument's silicone rubber feet may eventually blacken or scar lacquered surfaces. Use felt cloth pads to insulate the feet preferably use a PRELUDE musical instrument stand designed for your keyboard.

■ Do not place heavy objects on the instruments.

*. Do not place heavy instruments on the instruments. This may cause the instrument to tip over or break resulting in injury.

■ Volume

*. Very high volume levels can damage hearing. Avoid using the instrument at very high volume settings for long periods. Consult with a physician immediately if you experience impaired hearing or ringing in the ears.

■ Liquid Crystal Display (LCD) Precautions

*. Avoid subjecting the keyboard's LCD to strong impact, which can crack or break the LCD's glass creating the danger of personal injury.

*. Should the LCD glass ever crack or break, do not allow the liquid inside the LCD to come into contact with your skin, which can cause inflammation and reddening.

*. Should the LCD liquid get into your mouth, immediately wash out your mouth with water and then consult a physician.

*. Should the LCD liquid get into your eyes or on your skin, immediately flush with water for at least 15 minutes and then consult a physician.

■ Do not get onto the instrument or stand.*

*. Do not crawl on top of the instrument or its optional stand. Particular caution is required in homes having small children. This may cause the instrument or stand to tip over and break resulting injury.

■ Optional stand*

*. Carefully assemble the stand following the assembly instructions that come with it. Securely tighten all bolts, nuts, and fasteners, and make sure that you mount the instrument correctly onto the stand. Incorrectly or insufficiently tightening screws, or incorrectly mounting the instrument onto the stand can cause the stand to tip over or the instrument to fall off the stand, possibly leading to injury.

* The stand is available as an option.

CONTROL PANEL & TERMINALS

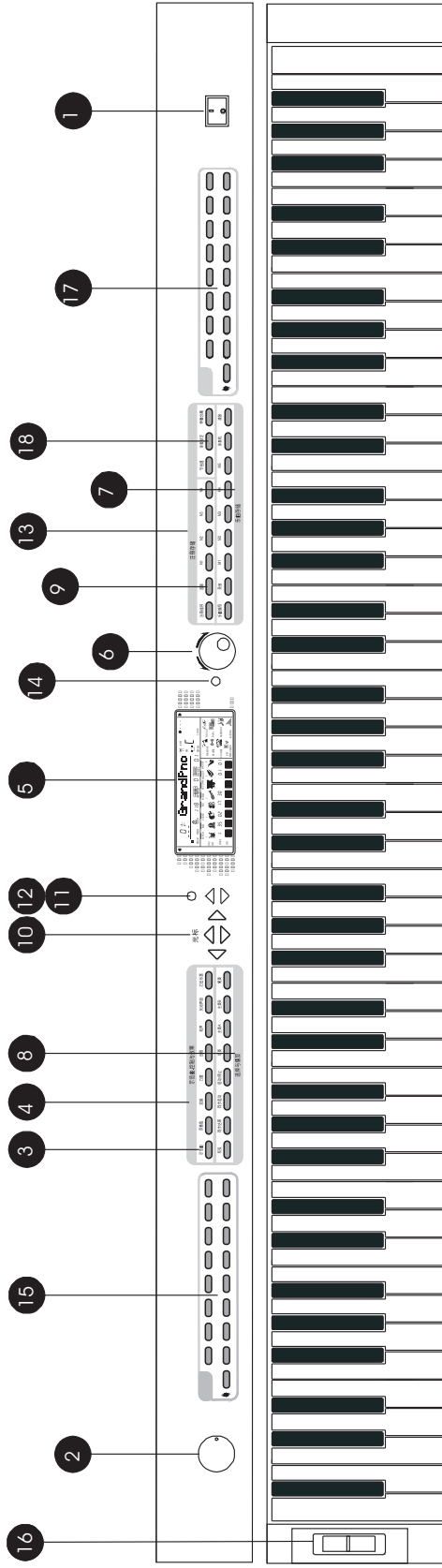

Control Board:

| | | | | | |
|----------------------------|-------|--|------------|-----------------------------|-------|
| ① POWER Switch | P. 10 | ⑥ SEARCH dial | P. 15 | ⑩ CURSOR buttons | P. 12 |
| ② MASTER VOLUME dial | P. 10 | ⑦ RECORD & PLAYBACK RECORD button | P.38 | ⑪ TEMPO button. | P. 29 |
| ③ DEMO button | P. 10 | PLAY/STOP button | P.10,39,42 | ⑫ FUNCTION button.. .. | P. 12 |
| | | REPEAT button | P.44 | ⑬ REGISTRATION MEMORY | P. 36 |
| | | MINUS CHANNEL button..... | P.43 | MEMORY button | P.37 |
| | | | | M1~M8 buttons | P.37 |
| ④ EFFECT | | ⑧ AUTO ACCOMPANIMENT | P. 27 | ⑭ MODE button | P. 14 |
| REVERB button | P.23 | SYNC START/STOP | P.30 | ⑮ STYLE button | P.29 |
| CHORUS button | P.25 | INTRO button | P.30 | | |
| PERCUSSION button..... | P.15 | MAIN A/B | P.31 | ⑯ PITCH BEND roller | P. 21 |
| 3DEFFECT button | P.26 | ENDING button | P.32 | | |
| TOUCH button | P.18 | START/STOP button | P.30 | ⑰ VOICE button | P. 14 |
| DUAL button | P.18 | | | | |
| HARMONY/ECHO button..... | P.20 | ⑨ TRACK button | P.33 | ⑱ ACMP FREEZE button. | P. 37 |
| ⑤ LCD screen | P. 12 | ACMP B/ S | P.33 | | |
| | | TRACK ON/OFF | P.33 | | |

External Terminals

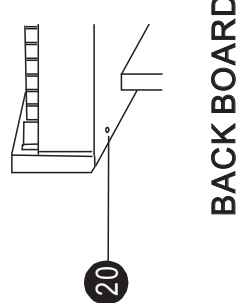
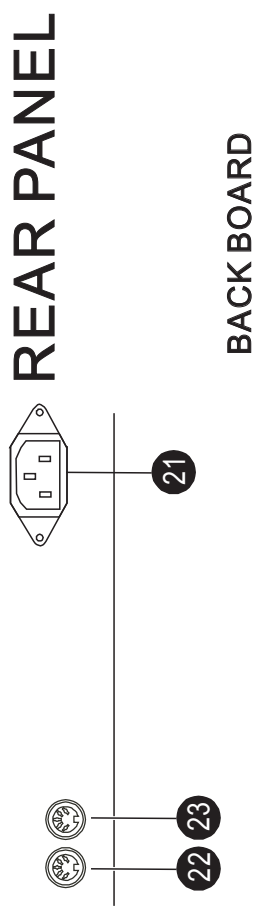

- 20 Headphone / Auxiliary Output P. 9
- 21 AC Adapter Socket P. 8
- Rear Panel
- 22 MIDI INP. 9,49
- 23 MIDI OUTP. 9,49
- Footswitch
- 24 Sustain Pedal P. 21
- 25 Damper Pedal P. 21

PREPARATIONS

■ Setting Up

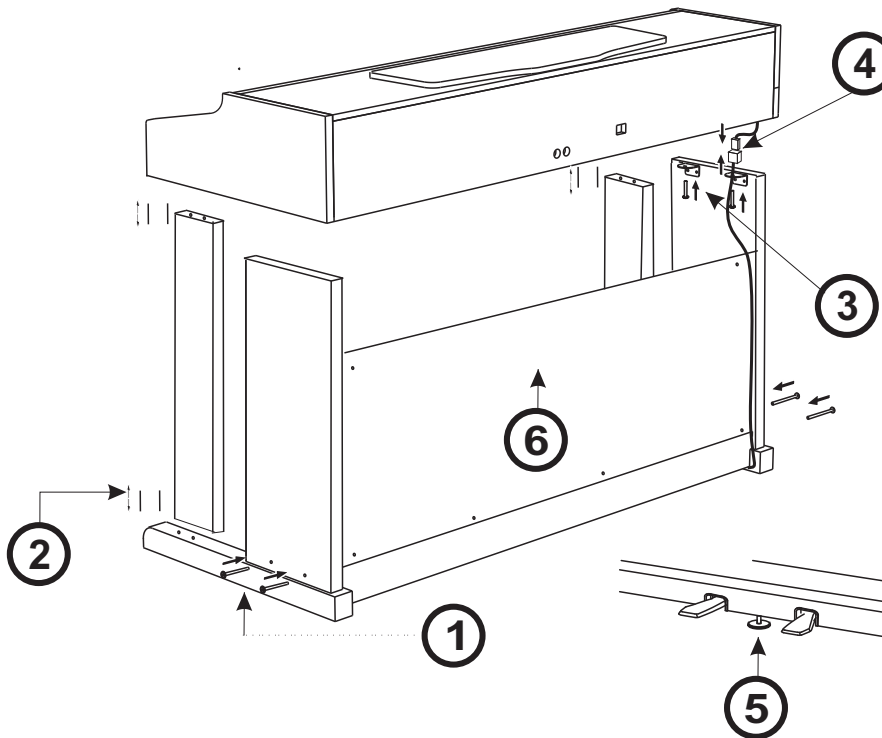

1. Fix the left and right feet on the ground board with 4 screws at each side.
2. Put 8 wooden screws into the small holes in the front left & right feet. 4 at each side. Then fix these feet separately on the ground feet.
3. Place the piano body onto the plank, and insert the top 4 wooden screws of the front feet into the relative holes of the body, then fix the body with the back feet with 4 screws at each side as shown in the illustration.
4. Connect the cable of foot switch with the socket cable (As shown in the illustration).
5. Move the screw between the sustain pedal and damper pedal right onto the ground, in order to pin up the pedal.
6. Use 6 screws to fix the baffle on the angle iron corresponding to the pedal and left & right back feet.

■ Basic Operation

- Open the keyboard cover, and set up the music stand.
- Before connecting to the alternating current, be sure to set the [POWER] switch to 0 position. Plug the power supply output into the AC socket, then connect the power supply input to the alternating current. Finally press down the 1, then the screen lights. Adjust the [MASTER VOLUME] dial according to your preference.

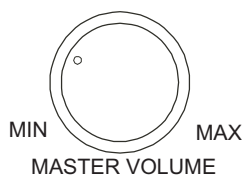

NOTICE

You should wait another 2 or 3 seconds to restart this instrument after you just turn it off, for it needs this time to make the internal circuit discharge completely. Otherwise, some abnormal phenomenon might occur during the performance.

■ Earphone and Audio output

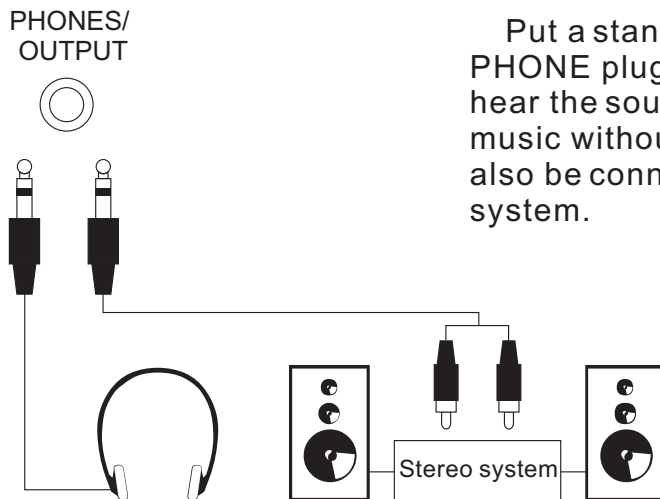

Put a standard earphone to connect the keyboard's PHONE plug. While connection is made, you may only hear the sound inside the earphone and practice the music without disturbing the others. This plug can also be connected to the speaker to have a stereo system.

■ MIDI input/output

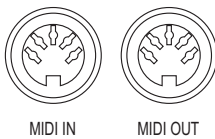

MIDI IN

Receive MIDI Data from the outside devices connected (e.g. Sequencer)

MIDI OUT

Send MIDI Data of this keyboard

LISTENING TO THE DEMO SONGS

■ *. Listen to the Music of the Memory

After installation, you may play this keyboard. Just experience its excellent performance. There are six Demos.

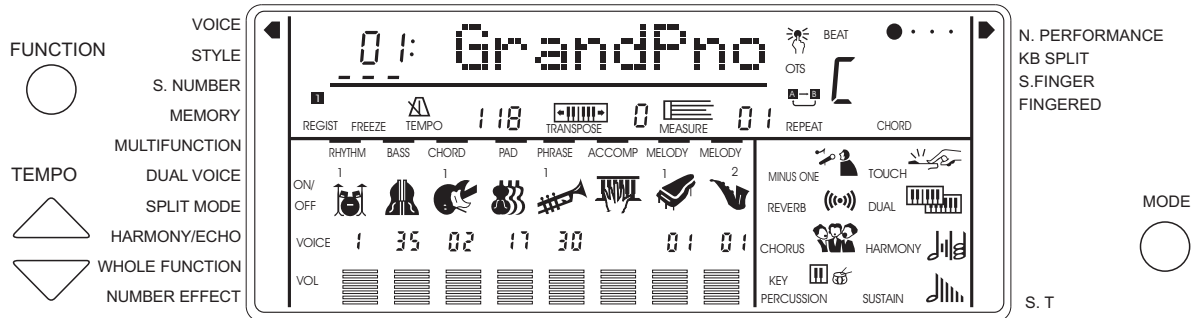

• 1. Tune on the POWER



POWER

• 2. Adjust the MASTER VOLUME dial to 1 / 4 circle. You can also adjust it during the playback

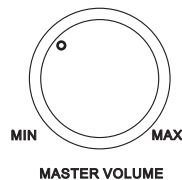

MASTER VOLUME

. It's always a good idea to set the keyboard volume at a relatively low level before playing.

• 3. Press the [DEMO] button

Press the [DEMO] button, this keyboard will play the music automatically. The name of the first song will appeared on the screen. This keyboard comes with 6 songs in memory while they will play orderly and circularly before being stopped.



- **4.To Select other demos**

During the demo playback, you can adjust the [SEARCH] dial to select other demo songs. Press [PLAY/STOP] button, and this instrument will play from the beginning of the song you have selected.

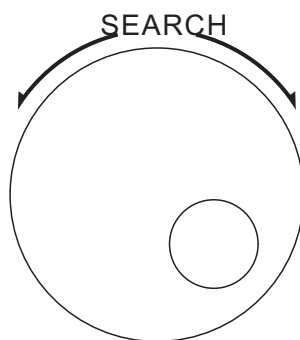
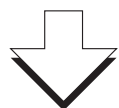
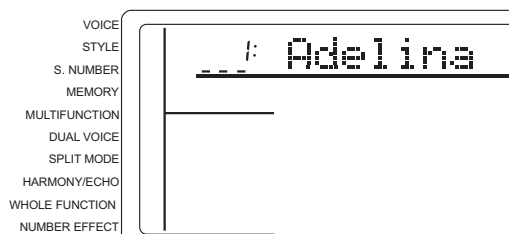

- **5.Quit**

Press [DEMO] or [PLAY/STOP] button to stop the playback, then press [VOICE] button to remove the function back to normal performance.



NOTICE:

If you press the [PLAY/STOP] button again after you stopped the playing all the demo songs in order, this instrument only plays the present demo song and stops when the song stops.

BASIC OPERATION

This instrument can display many important parameters in the screen. The following are the introductions about these parameters and icons in the screen, and as well as the basic operation of the panel buttons.

Cursor Buttons

These buttons are used to select various parameters in the screen. The selected parameter will either be added an underline, or be brightened, or flicker. The cursor will be moved in the direction according to the corresponding cursor button. Up and down cursor buttons can also be applied to select certain functions in the Function Team.

Function Team

By using Up and Down Function buttons you can select every function of this instrument, such as voice, style, song number and etc. The arrow in the screen points to the function you have selected. Pressing the Function buttons to move this arrow.

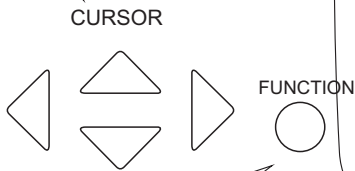

Parameter Icons

BEAT ● ● ● ● **Beat Icon**
This shows the current tempo and beat both in Song Mode and Style Mode.

A **REGIST FREEZE** **Registration Memory Icon**
This shows the current setting number of registration memory.

TEMPO **Tempo Icon**
This shows the tempo of the accompaniment and song playback.

VOICE
STYLE
S. NUMBER
MEMORY
MULTIFUNCTION
DUAL VOICE
SPLIT MODE
HARMONY/ECHO
WHOLE FUNCTION
NUMBER EFFECT

01: Gra

REGIST FREEZE TEMPO 118 TRANS

RHYTHM BASS CHORD PAD PHRASE

ON/OFF

VOICE 1 35 02 17 30

VOL

Accompaniment Track Parameters and Icons.

There are altogether 7 accompaniment tracks, such as Rhythm, Bass, Chord 1/2, Pad, and Phrase 1/2. Each track has its own switch, voice number and volume parameter. When one track is turned on, the corresponding icon appears in the screen.

RHYTHM BASS CHORD PAD PHRASE

 **Transpose Icon**
This shows the value of current transpose.

 **Measure Icon**
This shows the measure number of current song playback.

 **Repeat Icon**
This tells you the Points A and Point B when you editing the repeat section.

 **Chord Icon**
This tells you the current chord name in both Song Mode and Style Mode.

Mode
In the right part of the panel, there write four modes of this instrument. You can select each one by pressing [MODE] button. The arrow next to the modes points to the mode you current use.

Normal Performance. Normal Performance Mode

Keyboard Split The keyboard has been divided into two parts, which can be applied to two different voices.

Single Finger Chord Single finger accompaniment. Press one, two or three keys to decide the chord.

Fingered Chord Fingered accompaniment. The chord is played according to the exact chord you've played.

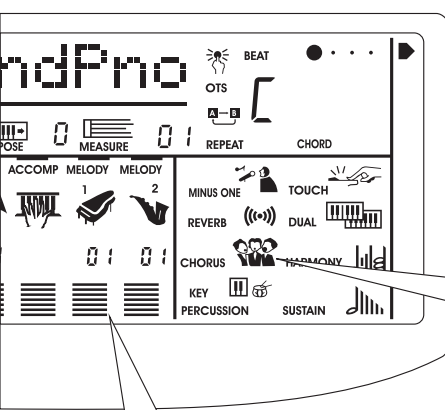



N. PERFORMANCE
KB SPLIT
S.FINGER
FINGERED

Function ON/OFF Icons

 **Minus One.**
It appears when this function is selected.

 **Reverb.**
It appears when Reverb Function is turned on.

 **Chorus.**
It appears when Chorus Function is turned on.

 **Touch.**
When this icon appears, the keyboard enables the Touch Response function.

 **Dual.**
It appears when Dual Function is turned on.

 **Harmony**
It appears when Harmony/Echo Function is turned on.

 **Sustain.**
It appears when Sustain Function is turned on.

 **Keyboard Percussion.**
It appears when the keyboard percussion is turned on.

Song Track Parameter and Icons
These three Song Tracks also can have switches, voice numbers and volume parameters just like the accompaniment tracks. Corresponding icon appears in the screen when the track is turned on.

ACCOMP MELODY MELODY



PLAYING THE PIANO

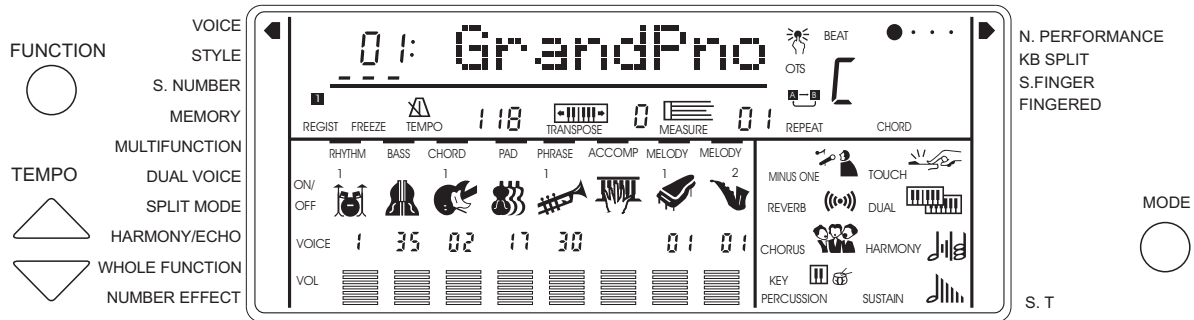

Selecting and Playing a Voice

This keyboard comes with 153 built-in voices and 10 percussion teams..Use the following procedure to select the voice you want to use.

■ 1. Selecting the normal mode

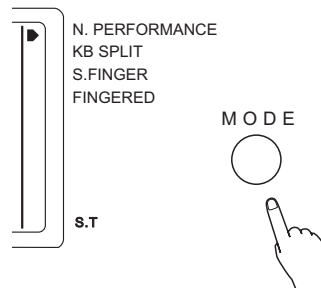

Under this mode, the keyboard can only perform a single voice. Press the [MODE] button in the panel until the arrow in the screen points to the normal performance position..

■ 2. Selecting the Voice Play function

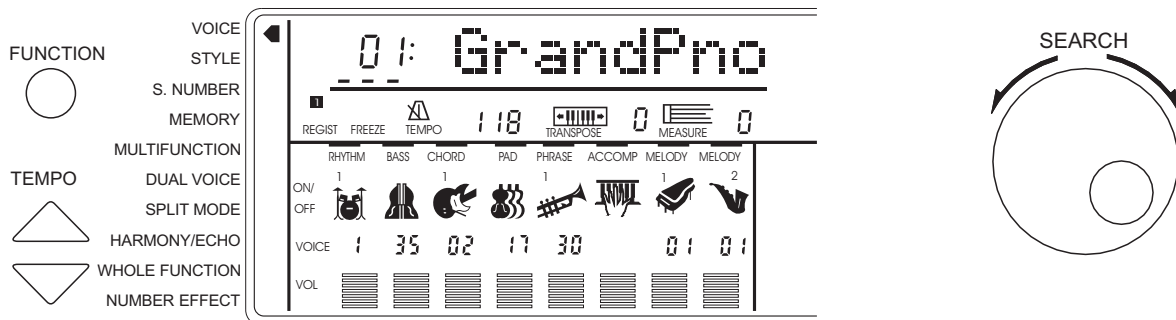

You have to select the Voice Play Function before performance. First press [FUNCTION] button until the arrow points to the [VOICE] position, then adjust the [SEARCH] dial to select the voice you desire or select directly one of the 32 common voices from the [VOICE] team. When the up-light of the [VOICE] A/B button is on, it indicates the voice you can select is among the down-row voices; otherwise, it is from the up-row voices.

■ 3. Selecting a Voice

You can adjust the [SEARCH] dial to select one voice from the total 153 voices. The voice list has been listed on the panel, and the present voice name and number shows in the first line of the screen.

[SEARCH] dial

During the Voice Play function, this dial can change the voice number in order.

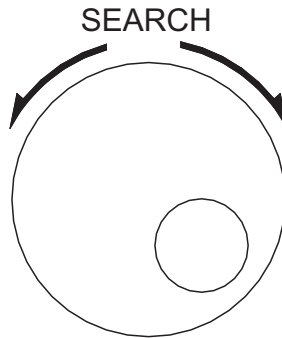

■ 4. Adjusting the Volume

First try the keyboard and then adjust the volume to a suitable place.

NOTICE

In the Whole Function team, the keyboard volume and the accompaniment volume can be separately adjusted. Holding down the [VOICE] button can quickly select the keyboard volume function. More information please refer to P. 46.

PERCUSSION

Press [PERCUSSION] button to turn on / off keyboard percussion voice. In keyboard percussion mode, you can play drum or other percussion on the keyboard. More information please refer to page 53.

• 1. Selecting the PERCUSSION FUNCTION

Keep pressing the FUNCTION button until the “arrow” points to Whole Function position. Then adjust the CURSOR (▲ ▼) till the “KbdPERC” appears on the screen.

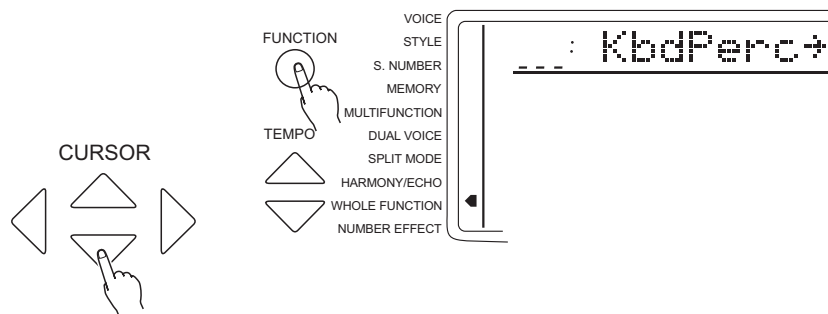

• 2. Selecting the PERCUSSION TEAM

Press the CURSOR button to enter in. Use [SEARCH] dial to select one group of the total 10 Percussion groups. The name of the one you select appears on the screen. You may also hold down the [PERCUSSION] button till the “arrow” in the screen points to the Whole Function position, and the name of present percussion group appears in the screen.

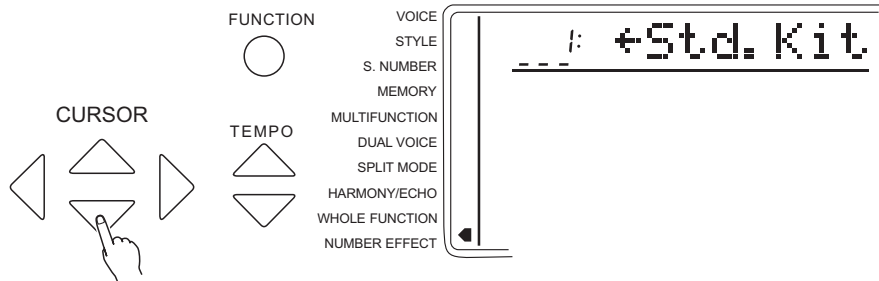

• 3. Percussion team

| | | | |
|----|-------------------------|----|---------------------------|
| 01 | STANDARD DRUMS | 02 | CHINESE PERCUSSION GROUPS |
| 03 | ROOM DRUMS | 04 | ROCK DRUMS |
| 05 | ELECTRIC DRUMS | 06 | T808 DRUMS |
| 07 | JAZZ DRUMS (same as 01) | 08 | BRUSH KIT |
| 09 | CLASSIC DRUMS | 10 | SFX KIT |

Notice:

*.while selecting the Percussion, you may not use the DUAL and the HARMONY function At the same time. These functions will automatically close.

KEYBOARD SPLIT MODE

*.Under this mode, the keyboard split to the right & left hands. Each can play a different Voice.

Example: BASS/PIANO

This mode splits the keyboard. One range is assigned a bass voice and other range is assigned a piano voice. The split point is B3 (Key No.59). It could be changed willfully. The voice of the right hand selects by normal mode, the voice of the left hand selects by the split mode. The following describes the details.

Press the [MODE] button till the “arrow” marks to the Keyboard Split. Thus you enter into the SPLIT MODE.

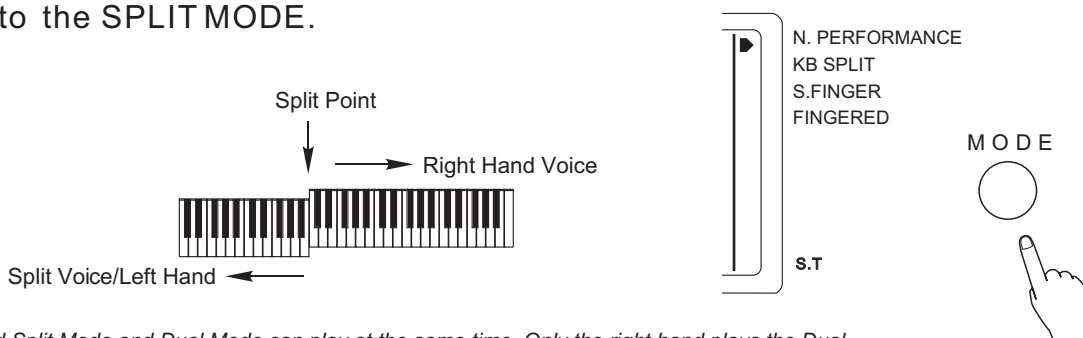

NOTICE

The keyboard Split Mode and Dual Mode can play at the same time. Only the right hand plays the Dual.

Changing the Split voice & relative parameters

1. Selecting the SPLIT MODE

Press the [FUNCTION] button till the “arrow” marks to the SPLIT MODE position

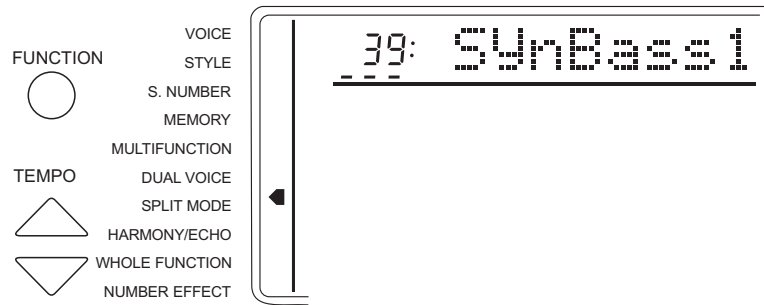

• 2. Selecting the proper function

Press the CURSOR (▲▼) to select the function you want. Then use the [SEARCH] dial to select the parameter setting. The current setting shows in the first line of the screen.

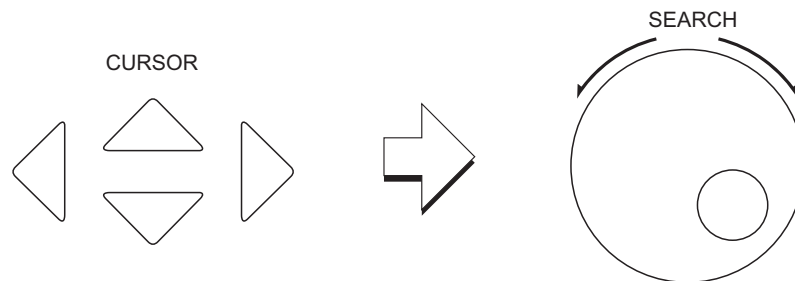

| Function | Explanation |
|-------------|--|
| Split voice | Change the tone of the left hand |
| S. Volume | Setting the tone of the left hand (0-127) |
| S. Octave | Change the volume of the left hand tone. -1: -1 Octave -2: -2 Octave +1,+2: +1,2 Octave |
| S. Revlv 1 | Setting the tone of left hand output Revlevel. From 0 (none) to 127 (Max Effect) |
| S. Cholv 1 | Setting the tone of left hand output Cholevel. From 0 (none) to 127 (Max Effect) |
| S. Pan | Setting the pan of left hand tone. From -7(left) to +7 (right) |
| S. Split | Setting the split point. The point itself belong to the left hand. Directly press one key to set the point and parameter appears on the screen. Or you can also use the CURSOR (▲▼) or the number button to select the key number. C1=36. centre C(C3)=60, C6=96. Split point could be any key from 0-127. (if use for MIDI, original point set as 59 (B2). |

NOTICE:

Pressing TEMPO + & - together can enable the initial setting of left hand voice parameter. To enter in minus numbers of S. Pan and S. Octave, you first press Tempo -- button, then press the number. The return level of Reverb and Chorus can be set in Number Effect function.

TOUCH RESPONSE

*. Press the [TOUCH] button may open/close the keyboard reaction function. While this function is on, the relative icon appears on the screen display. While the function is closed, the keyboard will produce the same volume to simulate instruments without such touch response, such as the CLASSIC ORGAN & PIANO.

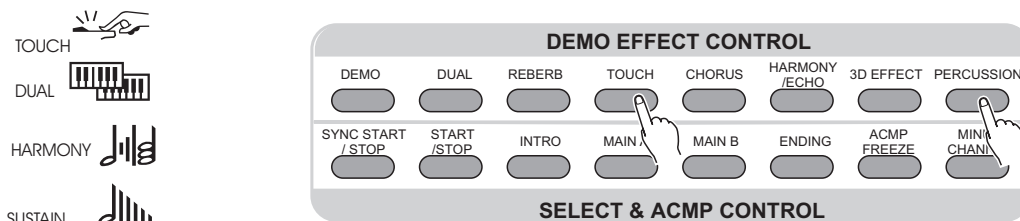

*. This function automatically open when the power switch turns on.
Press the [TOUCH] button to quickly select the parameter of the touch sensitivity.
More information please refer to P 48.

DUALVOICE

*This function make available the keyboard play two combined voices at the same time.
One voice is selected by the normal function, and another voice by this function.
While the function is selected, the relative icon appears on the screen display.

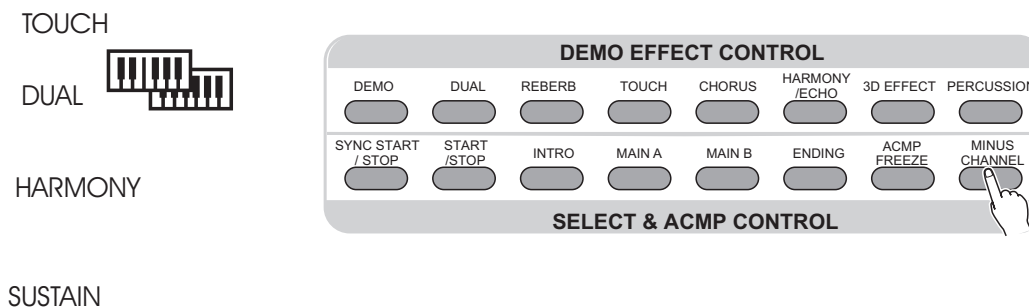

Selecting the relative parameters of DUAL

■ 1. Selecting the DUAL MODE

- Press the FUNCTION buttons till the “arrow” points to the DUAL Mode position.

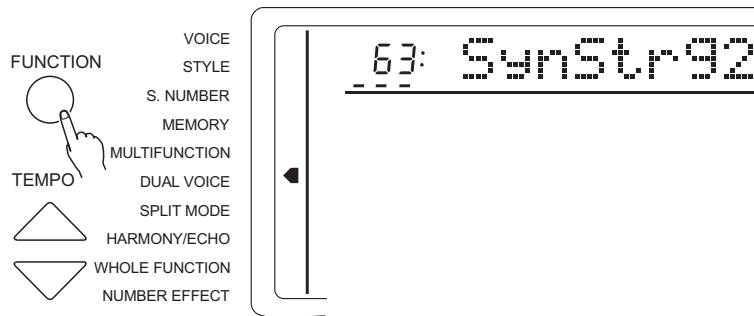

NOTICE

Holding down the [DUAL] button can quickly select the Dual Mode.

■ 2. Selecting/setting the function

- Select the function by the CURSOR button (▲▼). Then use the CURSOR (◀▶) button or numeric buttons to select the parameter setting. The current setting appears in the screen.

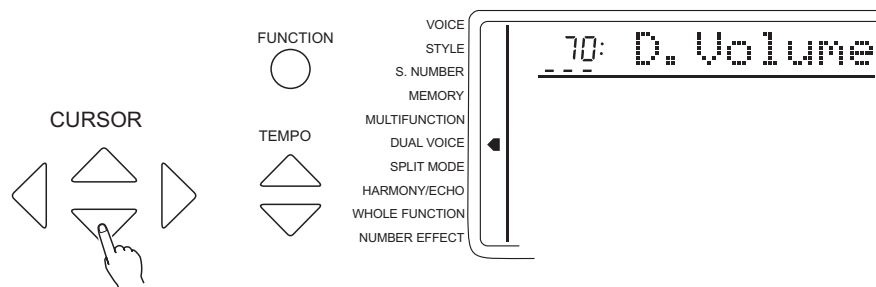

| Function | Explanation |
|-----------|--|
| Dualvoice | To select the second Voice, Its parameter appears in the display. This keyboard has 128 different voices. |
| D. Volume | Setting the volume of the voice (0-127) |
| D. Octave | Change the volume of the second octave Voice. -1: -1 Octave -2: -2 Octave +1,+2: +1,2 Octave. The original setting by the Function team. |
| D. Revlv1 | Setting the second voice of the dual output Rev-level. From 0 (none)to 127 (Max Effect) |
| D.Cholv1 | Setting the second voice of the dual output Cho-level. From 0 (none)to 127 (Max Effect) |
| D.Pan | Setting the pan of the dual. From -7(left) to +7 (right) |

NOTICE

Percussion can not be applied to Dual.

Pressing TEMP + & - at the same time can remove the second voice parameter to its initial setting.

The Octave pitch of the Main is changed in the Whole Function.

To enter minus number of the D. Pan and D. Octave, first hold down the CURSOR (▶) then press the number

The return levels of Reverb and Chorus are set in the Number Effect function.

■ 3. Quit

Press the [VOICE] button or select the other function to quit from this mode.

HARMONY/ECHO

Harmony Effect (01, 02) can add appropriate harmony notes to your melody. It depends on the chord played by your left hand.

Echo Effect (03--10) can add sustain effect to your right hand performance.

Press [HARMONY/ECHO] button to open / close this function. When this function is selected, relative icon appears in the screen.

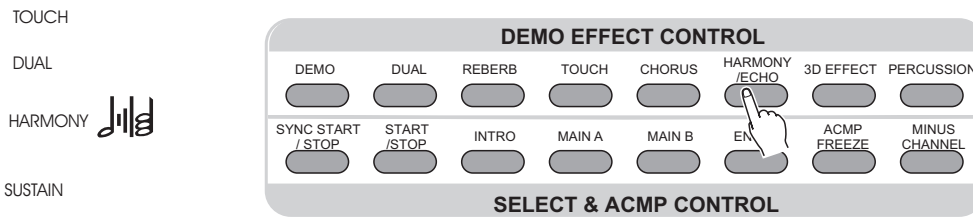

NOTICE

When the percussion is selected, Harmony / Echo function can not be used at the same time.

Under Normal Performance mode, Harmony function can not be used.

Harmony function can be applied to Single Finger and Fingered Accompaniment Mode.

Selecting the Harmony / Echo

1. Selecting the Harmony / Echo

- Press the [FUNCTION] button till the “arrow” points to the Harmony / Echo position.

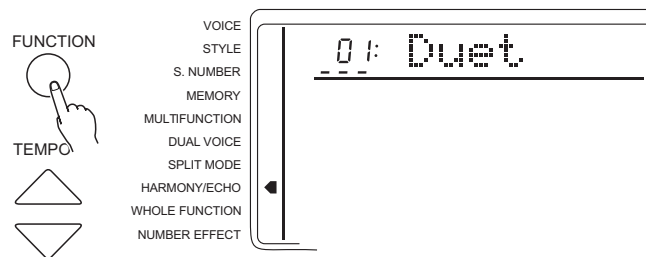





Holding down the [HARMONY/ECHO] button can quickly select the Harmony / Echo function.

2. Selecting the type of Harmony / Echo function

Adjust the [SEARCH] dial to select.

NOTICE

Press the CURSOR   buttons together to return to the initial setting of Harmony / Echo function type.

| TYPE | EXPLANATION | |
|-----------------|---|---|
| 01:Duet | Double-voice Harmony, 2nd voice lower than the melody | |
| 02:Octave | Add a bass octave to the melody | |
| 03:Tremolo 1/4 | Produce the tremolo 1 / 4 | |
| 04:Tremolo 1/6 | Produce the tremolo 1 / 6 | |
| 05:Tremolo 1/8 | Produce the tremolo 1 / 8 | |
| 06:Tremolo 1/12 | Produce the tremolo 1 / 12 | |
| 07:Echo 1/4 | Produce the Echo 1 / 4 |  |
| 08:Echo 1/6 | Produce the Echo 1 / 6 |  |
| 09:Echo 1/8 | Produce the Echo 1 / 8 |  |
| 10:Echo 1/12 | Produce the Echo 1 / 12 |  |

3. Quit

Press [VOICE] button or to select another Function to quit.

SUSTAIN

Sustain Pedal (23): Using this pedal can bring sustain effect to the melody.

MUTE

Mute Pedal (24): Using this pedal can diminish the sound of the melody.

TRANSCOPE

*.This function makes the keyboard transpose a half tone.

• 1. TO SELECT THE PARAMETER OF THE TRANSCOPE



Use the CURSOR buttons to select the number at right side of the “TRANSCOPE” in the screen display, which makes the number flash.

NOTICE:

*.Press the CURSOR ◀ ▶ buttons at the same time can remove the transpose parameter to 0.
The new parameter of the transpose will act on the following tone.

2. To set the parameter you need

- Use the [SEARCH] dial to select the parameter number(-12 to +12).0 stands for the standard pitch.

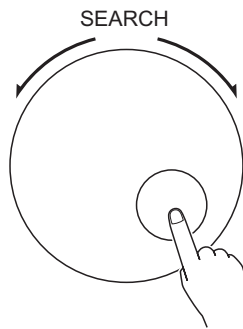

NOTICE:

*.Press the CURSOR ▶ and the number button at the same time to enter in minus number.

PITCH BEND

The roller on the left side of the keyboard could change the volume of the keyboard. Up to rise and down to reduce.

The extension could be set by the “PBRange” parameter by the Whole Function.

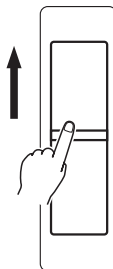

NUMBER EFFECT

USING NUMBER EFFECT

This instrument provides many Number Effects: 8 Reverbs; 8 Chorus; 3 D Effect to make your play perfect.

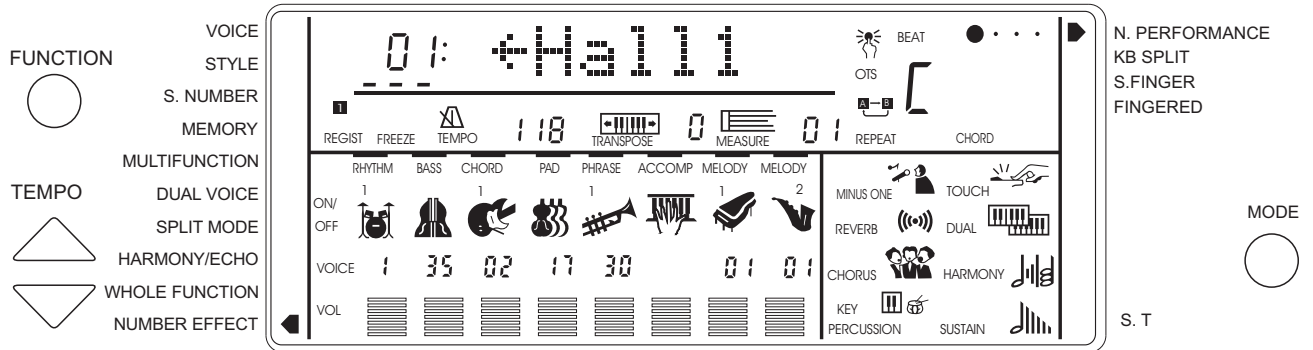

The Number Effects are : Reverb, Chorus, 3D Effect

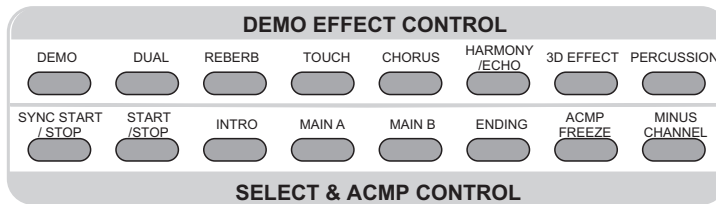

CHANGING THE REVERB EFFECT

Selecting the Reverb Style

• 1. Selecting the Reverb function

Press the FUNCTION button till the “arrow” points to the NUMBER EFFECT position. Then select the REVERB by the CURSOR (▲▼) buttons.

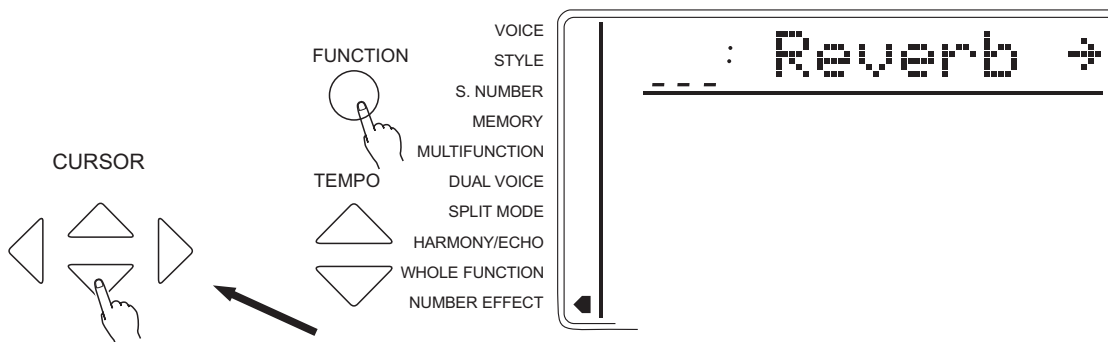

• 2. Selecting the Reverb type

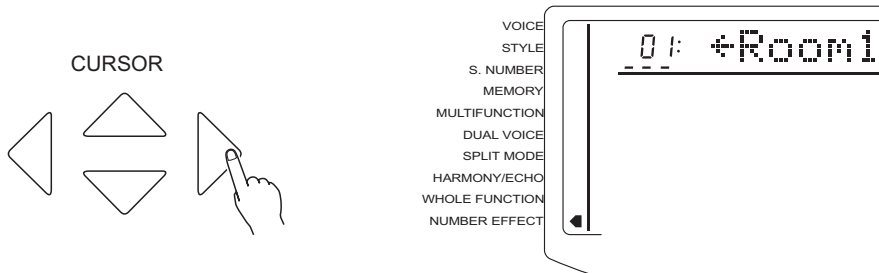

Use the  CURSOR to enter in. Then adjust the [SEARCH] dial to select one of the 8 Reverbs. The relative name appears in the screen. Also you can press [REVERB] button until the arrow in the screen points to the Number Effect position.



• 3. Quit

Press [VOICE] button or select another Function to quit.

Notice:

Pressing both CURSOR   buttons returns to the original Reverb setting.

Press the CURSOR  to return to the former page, 'Reverb' and then select the Chorus type.

Reverb Type:

:

| | |
|----------|-----------------|
| 01:ROOM1 | 02:ROOM2 |
| 03:ROOM3 | 04:HALL1 |
| 05:HALL2 | 06:PLATE |
| 07:DELAY | 08:PANNINGDELAY |

Setting Reverb Return Level

This parameter determinates the output of the Reverb Effect



• 1. Selecting the Reverb Return Level

Press the FUNCTION button till the “arrow” points to the NUMBER EFFECT position. Then select the RevRtnLv by the CURSOR   buttons.



Notice:

This setting influences all the voices. Every voice of the reverb send Level (including Split & Dual) could be set separately.

Press both CURSOR   buttons may return to the original setting of Reverb return level(64).

• 2. Setting Return Level

Use the [SEARCH] dial to adjust.



• 3. Quit

Press the [VOICE] button or select another function to quit.

CHANGING THE CHORUS

Selecting the Chorus Style

• 1. Selecting the Chorus Function

Press the FUNCTION button till the “arrow” points to the NUMBER EFFECT position. Then select the Chorus by the CURSOR   buttons.

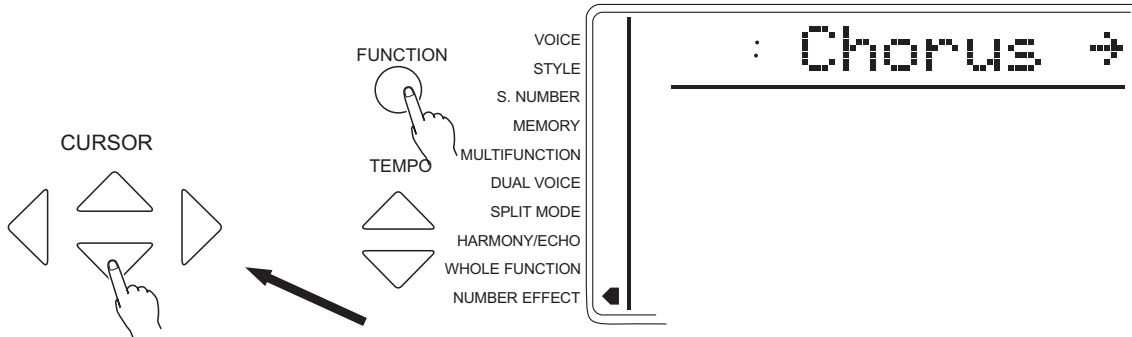

• 2. Selecting the Chorus style

Use the  CURSOR to enter in. Then adjust the [SEARCH] dial to select one of the 8 Chorus. The relative name appears on the display.

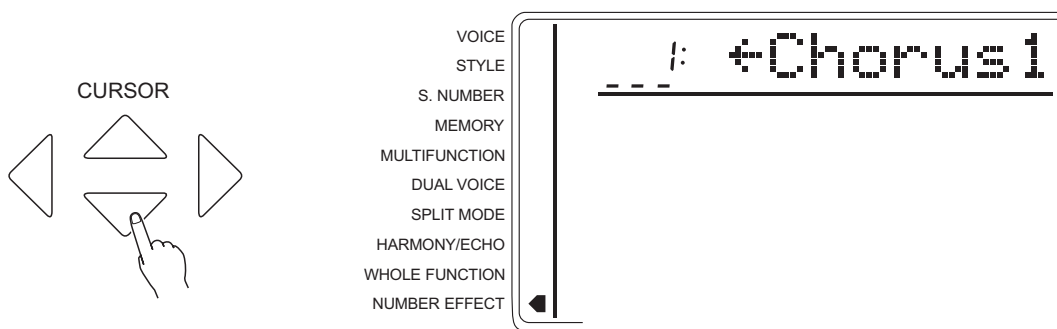

You may also press the [CHORUS] button till the “arrow” points to the NUMBER EFFECT position, and the current chorus name appears in the first line of the screen.



• 3. Quit

Press the [VOICE] button or select another function to quit.

Notice:

Pressing both CURSOR   buttons may return to the original setting of Chorus style.

Press the CURSOR  to return to the former page: 'Chorus' and then select the Reverb style:

CHORUS STYLE

01: CHORUS1

02: CHORUS2

03: CHORUS3

04: CHORUS4

05: FEEDBACK CHORUS

06: FLANGER

07: SHORT DELAY

08: SHORT DELAY WITH FEED-BACK

Setting the chorus Return level

This parameter determines the output level of chorus Effect.

- **1. Selecting the Chorus Return Level**

Press the [FUNCTION] button till the “Arrow” points to the NUMBER EFFECT position. Then select the ChoRtnLv by the CURSOR ▲▼ buttons.



64: RevRtnLv

- **2. Setting the Return Level**

Use the [SEARCH] dial to adjust. (00-127)

- **3. Quit**

Press the [VOICE] button or select another function to quit.

Notice:

This setting influences all voices. Each reverb send Level of the voice (including Split & Dual) could be set separately.

Pressing both CURSOR ◀▶ buttons may return to the original setting of Reverb return level.(64).

3 D EFFECT

*. Press the [3D EFFECT] button and the “arrow” points to the 3D EFFECT position of the WHOLE FUNCTION. Then you can open / close 3D EFFECT by pressing TEMPO + & -.

USING AUTO ACCOMPANIMENT

*.The following procedure describes how to use the keyboard's Auto accompaniment feature. PRELUDE Keyboard comes with 100 built-in styles, and provides with complete accompaniment band or rhythm.

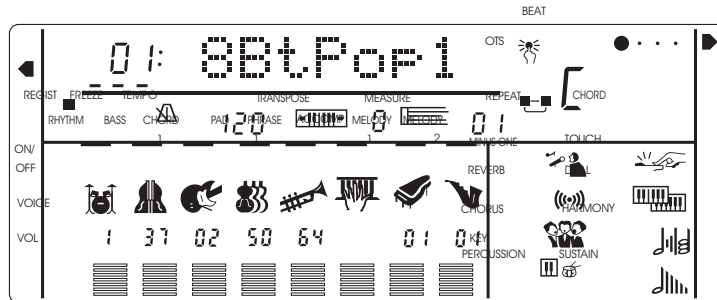

1. Selecting Accompaniment Mode

■ Keep pressing the [MODE] button (on the right side of the panel) till the arrow points to the SINGER FINGER or FINGERED MODE. “ ”

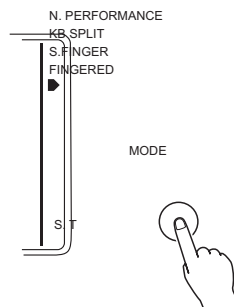

*.SINGER FINGER MODE

Under this mode, the chord accompaniment lets you play four types of chords with one or two fingers..

Example

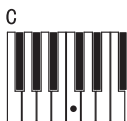

Major

Chord Types

Major chord---Press the root note of the chord.

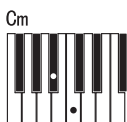

Minor

Minor chord----Press the rootnote together with the nearest black key to the left of it.

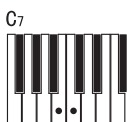

Seventh

Seventh chord----Press the root note together with the nearest white key to the left of it.

Cm7

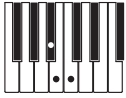

minor seventh

Minor seventh chord----Press the root note together with the nearest white and black keys to the left of it (three keys altogether).

*. FINGERED MODE

Under this mode, the left keyboard(In Style mode, the split point always lays at key no. 54) plays the accompaniment chord. The following chords listed are recognizable. (Take C chords for example, notes in parentheses can be omitted.)

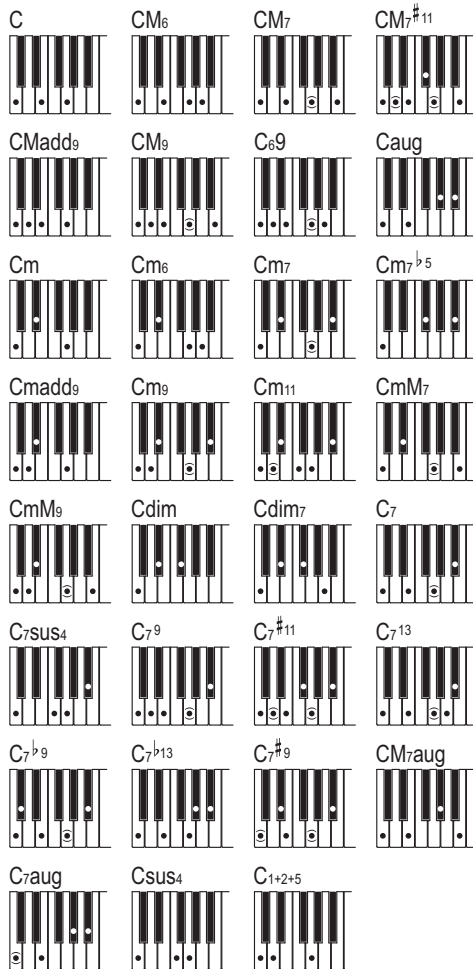

| CHORD NAME | ABBREVIATION | |
|----------------------------|--------------|-------------------------|
| MAJOR | M | 1-3-5 |
| MAJOR SIXTH | M6 | 1-3-5-6 |
| MAJOR SEVENTH | M7 | 1-3-(5)-7 |
| MAJOR SEVENTH | | |
| SHARP ELEVENTH | M7#11 | 1-(2)3#4-(5)-7 |
| MAJOR ADD NINTH | Madd9 | 1-2-3-5 |
| MAJOR NINTH | M9 | 1-2-3-(5)-7 |
| MAJOR SIXTH ADD NINTH | 69 | 1-2-3-(5)-6 |
| AUGMENTED | aug | 1-3-#5 |
| MINOR | m | 1b3-5 |
| MINOR SIXTH | m6 | 1b3-5-6 |
| MINOR SEVENTH | m7 | 1-b3-(5)-7 |
| MINOR SEVENTH | | |
| FLATTED FIFTH | m7b5 | 1-3-5-7 |
| MINOR ADD NINTH | madd9 | 1-2-3-5 |
| MINOR ADD NINTH | m9 | 1-2-3-5 |
| MINOR MAJOR ELEVENTH | m11 | 1-3-(5)-7 |
| MINOR MAJOR NINTH | mM9 | 1-2-3-(5)-7 |
| DIMINISHED | dim | 1-3-5 |
| DIMINISHED SEVENTH | dim7 | 1-3-5-6 |
| SEVENTH | 7 | 1-3(5)-7 |
| SEVENTH SUSPEND FOURTH | 7sus4 | 1-4-5-7 |
| SEVENTH NINTH | 79 | 1-2-3-(5)-7 |
| SEVENTH SHARP ELEVENTH | 7#11 | 1-(2)3-#4-(5)-b7 |
| SEVENTH THIRTEENTH | 713 | 1-3-(5)-7 或2-3-5-6-7 |
| SEVENTH FLATTED NINTH | 7b9 | 1-2-3-(5)-7 |
| SEVENTH FLATTED THIRTEENTH | 7b13 | 1-3-5-6-7 |
| SEVENTH SHARP NINTH | 7#9 | (1)-#2-3-(5)-7 |
| MAJOR SEVENTH | | |
| AUGMENTED | M7aug | 1-3#-5-7 |
| SEVENTH AUGMENTED | 7aug | (1)-3-#5-7 |
| SUSPEND FOURTH | sus4 | 1-4-5 |
| ONE PLUS TWO PLUS FIVE | 1+2+5 | 1-2-5 |

NOTE:

- Notes in parentheses can be omitted.
- Playing two same root keys in the adjacent octaves produces accompaniment based only on the root.
- A perfect fifth (1+5) produces accompaniment based only on the root and fifth which can be used with both major and minor chords.
- The chord fingerings listed are all in "root" position, but other inversions can be used with the following exceptions: m7, m7 b 5, 6, m6, sus4, aug, dim7, 7 b 5, 6(9), 1+2+5.
- Inversion of the 7sus4 and m7(11) chords are not recognized if the notes shown in parentheses are omitted.
- The auto accompaniment will sometimes not change when related chords are played in sequence (e.g. some minor chords followed by the minor seventh).
- Two-note fingerings will produce a chord based on the previously played chord.

■ 2. Selecting the STYLE Function

Press the [FUNCTION] button till the “arrow” points to the STYLE position.

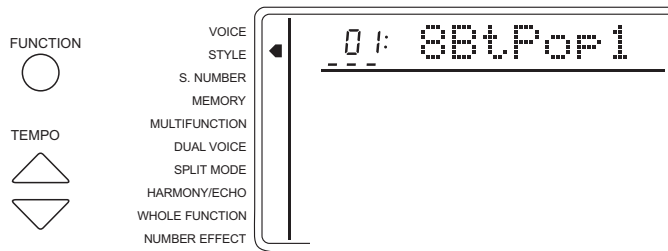

*. Keep pressing the [STYLE] button to quickly select the ACCOMP VOL parameter in the whole function.

[Refer to P 47]

■ 3. Selecting a STYLE

*. Use the [SEARCH] dial to select one of 100 style of this instrument. More information please refer to P. 54.

In the front panel there are 32 commonly-used accompaniment styles.

The current style and number show in the screen.

*. While [A/B]up- light on, the voice you select is the down side, while the down-light the up side style.

■ 4. Setting the TEMPO

Every Style type has its own Tempo. It displays on the right side of the TEMPO mark. While the Accompaniment is started, this Tempo will not be changed even if you select any other Style at the same time.

To select the Tempo of 40-240/tempi by the TEMPO ▲▼ buttons. Every press to increase one tempi. Keep pressing to quicken the procedure. Press the TEMP ▲▼ at the same time to return to the original tempo.



You may also select the Tempo parameter by the CURSOR buttons. Use the CURSOR ◀▶ buttons or the NUMBER buttons to change the parameter. Press the CURSOR ◀▶ buttons at the same time to return to the original tempo. You can select this while during or before the performance.

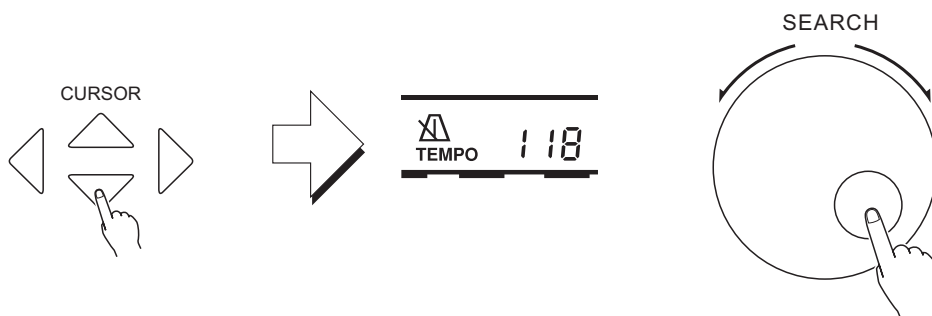

■ 5 Start the Accompaniment

*. Direct start:

Press the [START/STOP] button, rhythm will start playing the current choice A or B without Bass and chord.

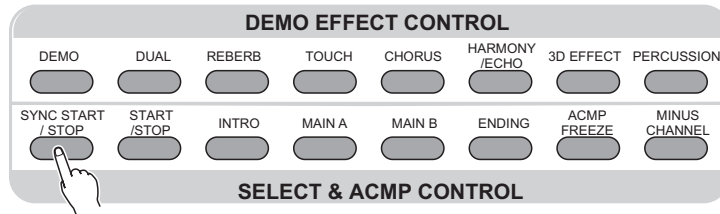

*. Started from Intro, and then play the Main [A]

Press the [INTRO] button, and then press the [A] to make the light on. (If the light is already on, then you do not have to press this button.)

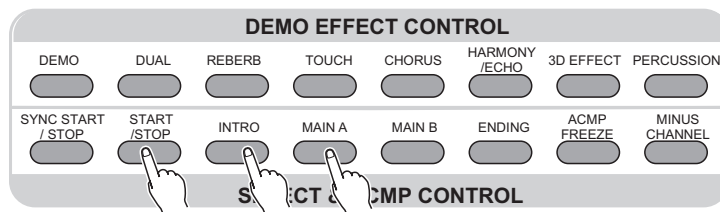

*. Started from Intro, and then play the Main [B]

Press the [INTRO] button, and then press the [B] to make the light on. (If the light is already on, then you do not have to press this button.)

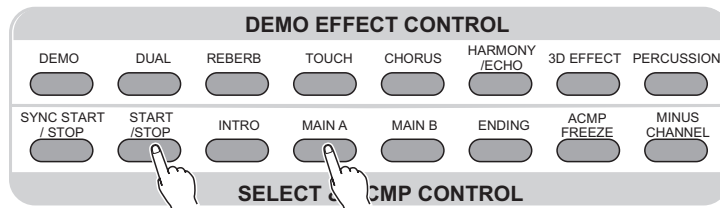

*. SYNC Start

Press the [SYNC/STOP] button to enable you to play any style of the accompaniment while you first press the Split Point in the left keyboard. 54(F#3).

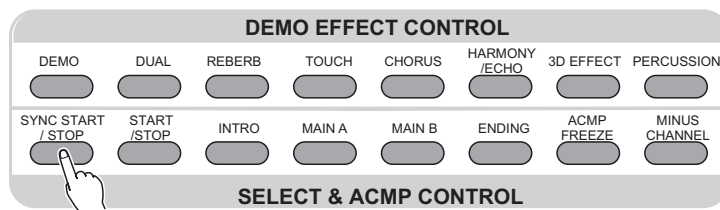

Pressing the [SYNC/STOP] button only makes the accompaniment play after you first press a key on the left hand of the keyboard. Pressing the [SYNC/STOP] button first and then press the [INTRO]& [MAIN] buttons enables you to have the Sync with intro. While selecting the Sync style, tempi light flashes and shows the current tempo. Pressing the [SYNC/STOP] button again before playing will cancel this function.

Notice:

*. While playing, you may also select the [INTRO] button to play Intro.

*. Press the [SYNC/STOP] button to stop the accompaniment and enter into the Synchro.

*. The Split Point setting could be changed by the Whole Function.

■ 6. Using Auto Accompaniment

This keyboard will automatically recognize the chord while you are playing the left part, and it can play the proper bass chord for the current style. Even if your left hand has released the keys, it will still automatically continue playing. The name of the chord displays in the screen.

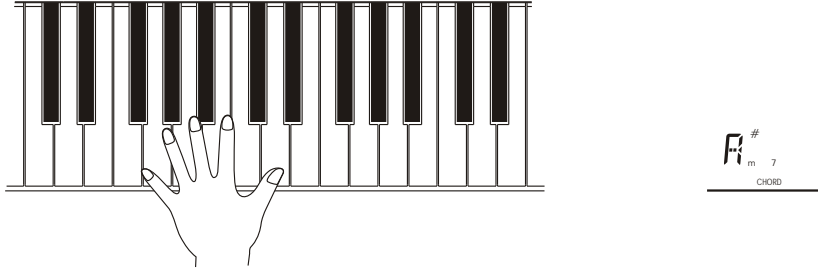

*. BEAT display

In the BEAT part shows current Beat.

| | 4/4 time | 3/4 time |
|----------|----------|----------|
| 1st beat | ● ● ● ● | ● ● ● ● |
| 2nd beat | ● ● ● ● | ● ● ● ● |
| 3rd beat | ● ● ● ● | ● ● ● ● |
| 4th beat | ● ● ● ● | BEAT |
| | BEAT | |

■ 7. To select Main (A) or (B)

While playing, you can freely choose Main [A] or [B]. After you press [A] or [B], this keyboard will automatically add in a kind of fill-in(altogether 2 kinds), in order to make the change smoothly. This is also available for the same part. For example: While you are playing Main [A] and press the Main [A] at the same time, this keyboard will quickly fill in, and then continuously play the Main [A]. The same for different Main.

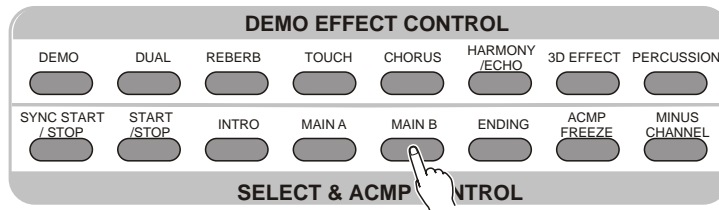

■ 8 Stopping the Auto Accompaniment

Press [START/STOP] button to stop accompaniment. Or press [ENDING] button to stop it after the ending. The Ending will start from the beginning of next measure.

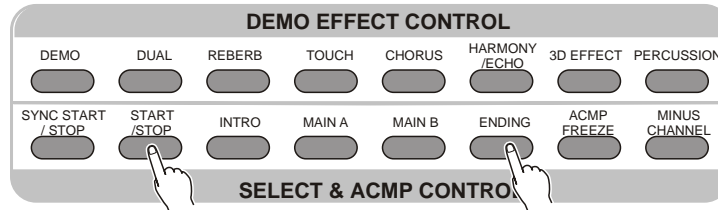

*. *The volume of the Accompaniment could be set by the Whole Function. (Refer to P47)*

*. Quiescence Accompaniment Function

Under the function of Single Finger & Fingered, after you stop the accompaniment, if you play on the left part of the keyboard, it will continue playing proper bass chord that suitable for your performance.

ACCOMPANIMENT TRACK CONTROL

*. This keyboard has 7 Accompaniment Tracks: RHYTHM, BASS, CHORD1/2, PAD and PHRASE1/2. After a style is selected, CHORD1 and PHRASE1 will display in the screen. Press FUNCTION button till the “arrow” points to the track position. Press the CURSOR ◀▶ buttons can select 7 tracks. Then you can use CURSOR ◀▶ buttons to open/close the Accompaniment Track separately.

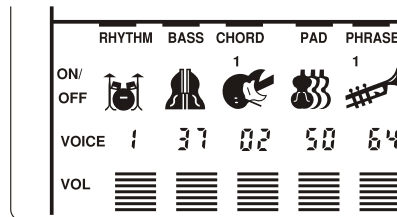

*.The content of Accompaniment Track:

- RHYTHM Provide the Percussion or Drum voice
- BASS Provide different Bass voices, according to the style, such as ELECTRIC BASS; ACOUSTIC BASS
- CHORD 1&2 Provide the Rhythm Strings accompaniment, like the voice of Guitar and Piano.
- PAD Provide the long chord, such as strings and Organ.
- PHRASE 1&2 Provide the decorations, including the separate Chord, strong note, etc.

Notice:

While a style is selected, The track including the data will display in the screen.

■ Big & Small Accompaniment

This is the simplest way to control the accompaniment track. Using this button can open / close certain accompaniment track. If the Big Accompaniment is selected, all the tracks are open; if the small one, the icons for some tracks disappear.

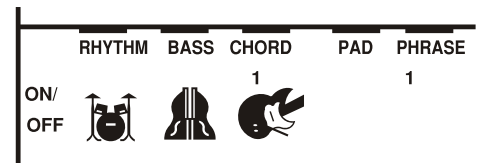
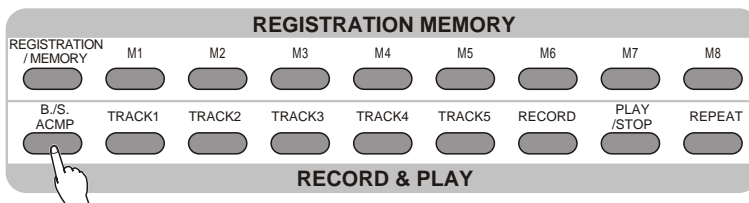

NOTICE

If a new style is selected, the instrument will automatically select the Big Accompaniment mode.

The accompaniment selects the tracks according to the style. Sometimes, some tracks are closed, and you are not able to open them.

■ Mute the Accompaniment

This instrument provides you with live control to the accompaniment. Pressing corresponding track number button can open / close (mute) that track. When the track is muted, its icon disappears. For example: Direct pressing PHRASE 1 / 2 track button can close these two tracks.

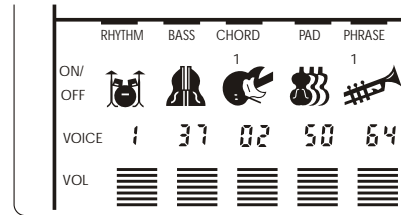
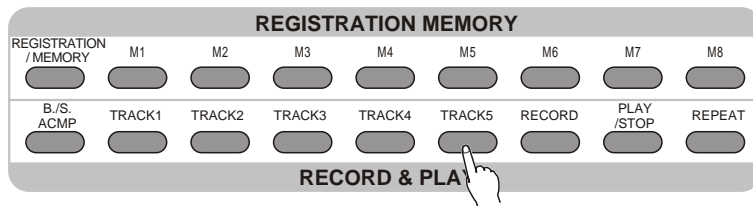

Holding down the track number buttons can fast enter in the track. Using Tempo + & - buttons to open / close the tracks. This method can close PHRASE 1, PHRASE 2, CHORD 1, CHORD 2 separately.

■ Changing the Accompaniment Voice

Move the cursor to track voice position, and it flickers. Then use cursor (◀▶) buttons or number buttons to select the voice number. The accompaniment uses different voice from what printed on the panel.

RHYTHM track can only use voices from 1 to 8, and other tracks can select from 00 to 152.

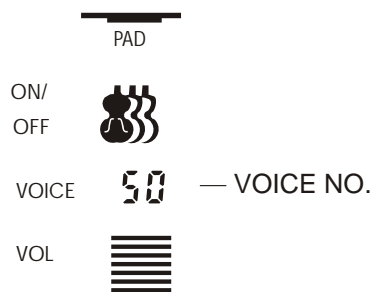

■ Adjusting Accompaniment Volume

Adjusting the volume of each track can produce proper reverb effect. Move the cursor to the track volume position, and it then flickers, then set the value. The bigger the value, the higher the volume, and it can keep its peak volume.

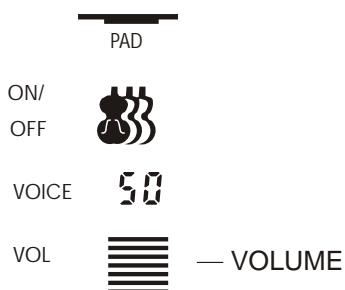

NOTICE

If selecting another style, the accompaniment track parameters will recover. You can use registration memory function to save the parameter setting you need.

After changing the voice or volume, you can press Tempo + & - at the same time to recover the initial setting.

Track data has effect on every section (Intro, Ending, etc). During the song record, a single track is muted, and changing the accompaniment track voice and volume function have no effect.

CHANGING THE SPLIT POINT OF ACCOMPANIMENT TRACK

• 1. Selecting the split point function

Press the FUNCTION button on the front panel till the “arrow” points to the Whole Function. Then use the CURSOR (▲▼) button to select the AccSpPNT.

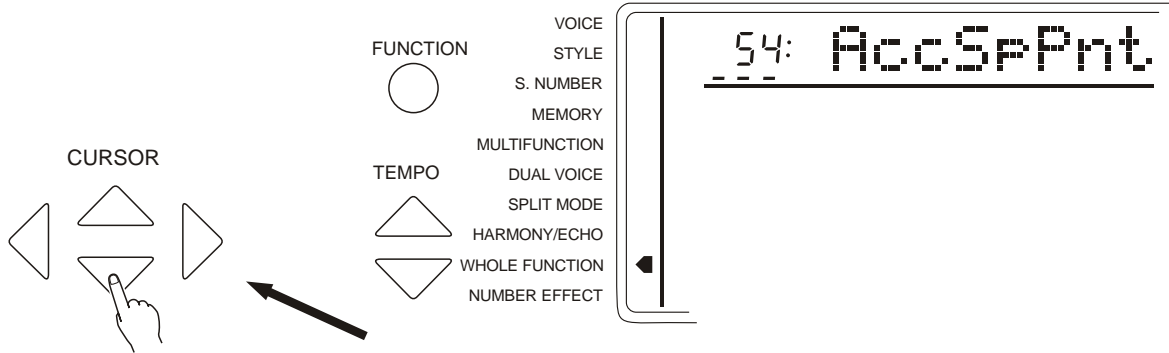

• 2. Setting the Data

Input directly by the Key(of the keyboard). Or select by the [SEARCH] dial. The relative name appears in the screen. The lowest C1 keyboard number is 36; centre C (C3) is 60; and highest C6 is 96. Split point number could be any of 0-127(though it has overpassed the range of this instrument) in order to make easier using the MIDI Function.

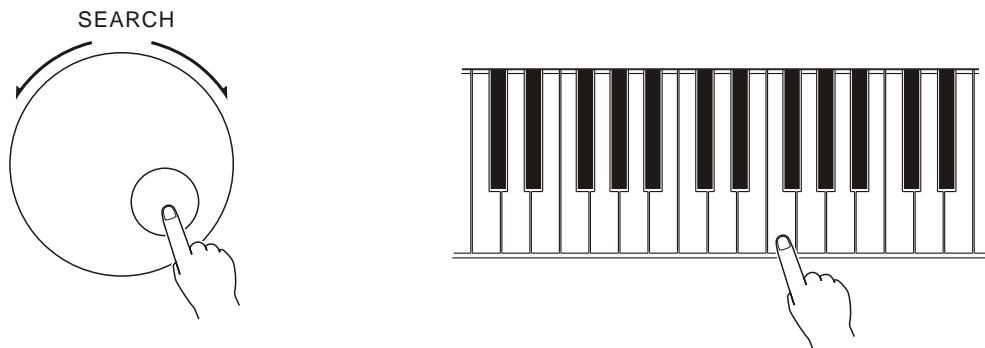

• 3. Quit

Press [VOICE] or select other function to quit.

Notice:

Split point is the highest note of the left hand part.

Press the CURSOR (◀▶) buttons together can return to the original setting 59.

REGISTRATION MEMORY

REGISTER PANEL SETTING

The memory of this Keyboard can record 8 parameters of panel setting. It could be recalled at your service.

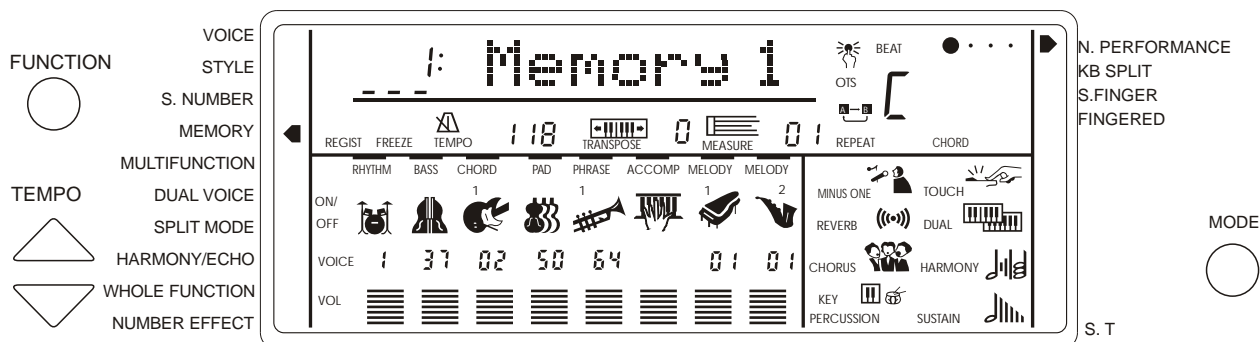

■ 1. Setting the control buttons needed.

The following setting could be saved.

- *. Voice number
- *. Split voice Parameters
- *. Dual parameters
- *. Harmony/Echo type
- *. Volume of the keyboard
- *. Octave
- *. Rev Level
- *. Pan
- *. Touch sense
- *. P. B Range
- *. Metronome (on/off)
- *. Percussion team
- *. 3D Effect (on/off)
- *. Chorus Level
- *. Style number
- *. Accompaniment Vol
- *. Split Point (Accompaniment function)
- *. Reverb (Reverb RevRtnLv)
- *. Chorus (Chorus ChoRtnLv)
- *. Tempo. Transpose
- *. Accompany vol data(open/close;Vol;Ttone)
- * Mode (Normal; Duel; Fingered; 8 Finger)

■ 2. Registering the setting

while holding down the Memory button, press a memory number button (M1-M8) to make this keyboard memory a new setting. The former data will be erased.

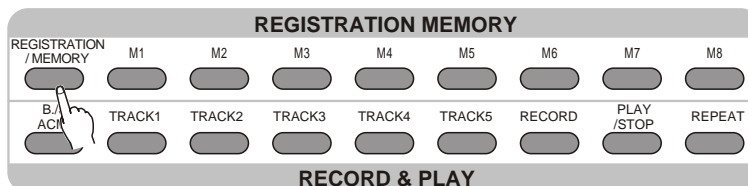

RECALLING THE REGISTERED SETTING

*After select a Memory Bank, press the registration memory number button may recall the corresponding parameter setting. The register number will appear in the screen at the REGIST position. And the parameters will appear in the screen.

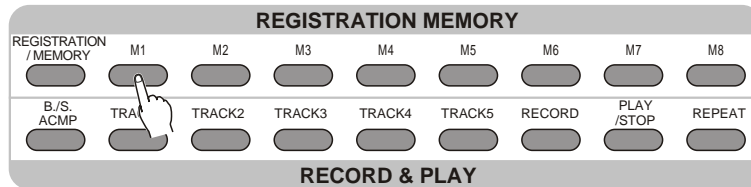

ACCOMPANIMENT FREEZE FUNCTION

* Under this function, recalling a memory number will not change the parameters of the accompaniment. This will not disturb your performance, while using different memory settings Press the [FREEZE] button to open/close the function. When this function is on, the word FREEZE appears in the screen.

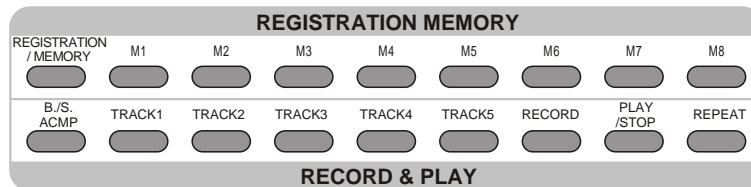

Notice:

Selecting different memory bank will not close the FREEZE function.

SONG RECORDING

*. You can record and replay a song by this keyboard. The song includes the accompaniment and the melody you played. The song track includes an accompaniment track and two melody tracks. Song 5 is a user song(to record your performance). This keyboard lets you record a complete user song at one time.

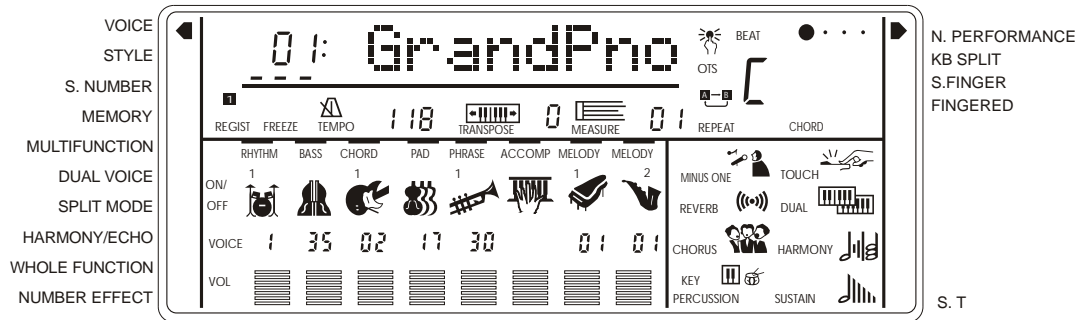

MELODY TRACK RECORDING

Melody Track Recording can control the following operation and data.

- *. Note ON/OFF
- *. Touch
- *. Voice number
- *. Octave
- *. Vol of the Keyboard
- *. Tempo (accompaniment and melody track)
- *. Voice number of the Dual (vol; Octave; Rev; Chorus Level; Pan)
- *. Range
- *. Rev
- *. Duel switch
- *. P.B Range

*. It records only at the beginning of a song. Any changes made during recording will not be recorded.

• 1. Selecting a Song Number

If needed, press the FUNCTION button to select a S. NUMBER. Then use the [SEARCH] dial to select Song the song.

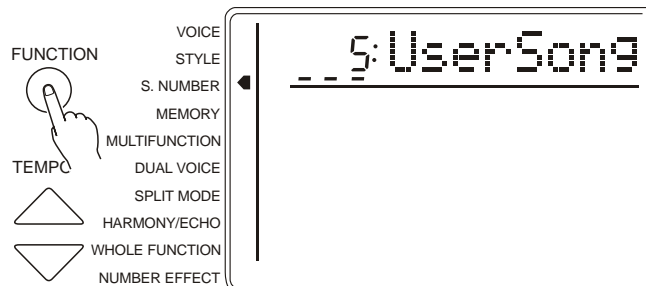

- **2. Selecting the Voice and Setting the relative parameters**

After selecting the voice, you can set the Effect and other parameters.

Notice:

You can not record in Split Mode. While preparing for recording, the keyboard automatically selects the normal mode.

- **3. Entering into the Melody Track Recording Preparation**

Press the [RECORD] button, and the light flashes. While REC appears at MELODY 1 position, it shows that it is ready. Use [SEARCH] dial to select another Melody Track.

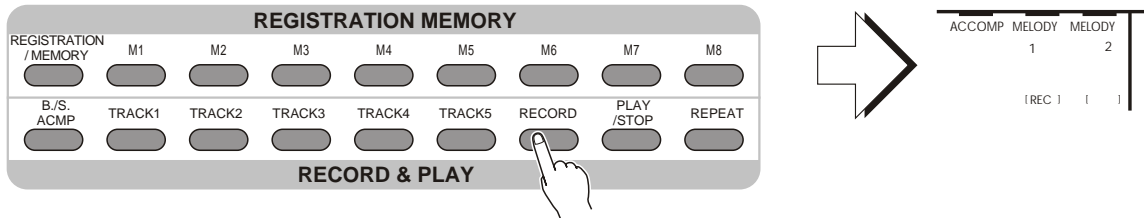

Beat flashing shows the current tempo. If the BEAT function is on, it flashes by the tempo.

Notice:

If the former recorded accompaniment track is on (the relative mark shows in the screen), It could be monitored while recording. If you do not need the accompaniment, press the FUNCTION button to the Song Track position and use the CURSOR (◀▶) to select the Accompaniment track. Use the CURSOR (▶) to close it. Once you press the REC button, this Keyboard will automatically select the USER SONG.

The melody track volume is the current volume of the keyboard.

Each time you could only record one Melody track.

Press the REC again to quit the record standby state.

After entering into the record standby, the keyboard will set the measure as 01. (Not From the pointed measure.)

- **4. Recording**

Just play the keyboard or press the [PLAY/STOP] button to start recording. Time indicator shows the current Time.

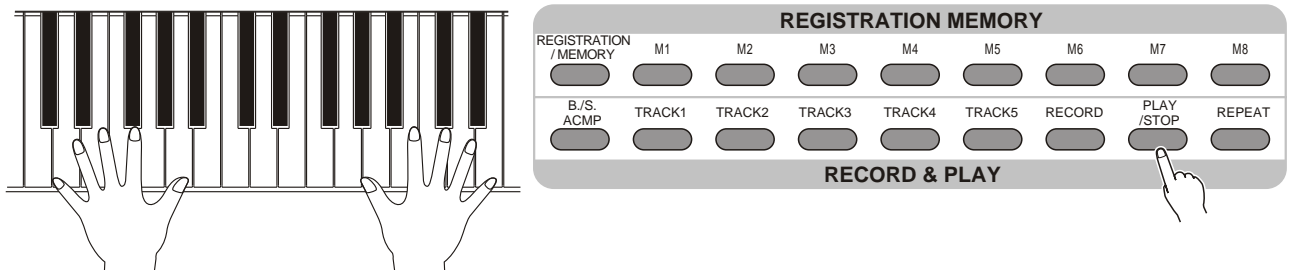

Notice:

Song recording will delete all the former data of the same track.

Recording proceeds by measures. If you stop between the measure, the rest will be recorded as pause.

If the music Memory is full, the letter FULL will appear on the screen. The recording Stops.

Only the Voice number (Voice function) shows in the Melody Track. (No Dual)

- 4. Stop recording

Press the [PLAY/STOP] button, and REC disappears and the volume of the Melody track appears in the screen.

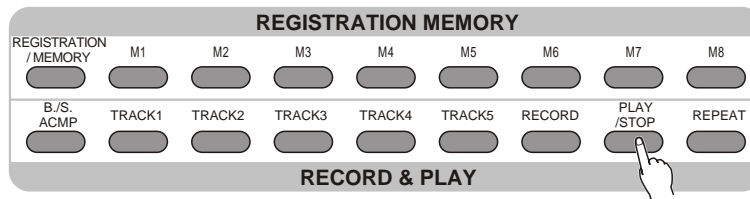

ACCOMP TRACK RECORDING (WITH/WITHOUT MELODY)

Song accompaniment track can record the following data and operation:

- *. Section change (INTRO, FILL IN, ENDING) *. Style number
- *. Chord change, current value *. Melody track on/off, Voice, Volume change
- *. Rev *. Accompaniment volume
- *. Chorus
- * *Only start recording when the song begins, and the changes made during the performance will not be recorded.*

- 1. Selecting a Song number

If needed, press the FUNCTION button to select the Song number. Then adjust the [SEARCH] dial to select Song Number 5(USER SONG)

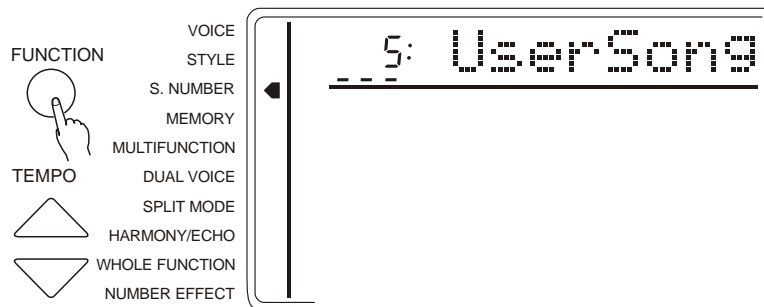

- 2. Selecting Single Finger or Fingered Style

Select Single Finger or Fingered mode and any style to suit the song.

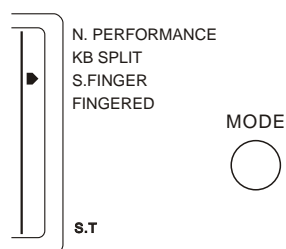

• 3. Entering into ACCMP / Melody Recording Preparation

Press the REC button, and the light flashes. "REC" appears at the ACCOMP and MELODY position. Use the [SEARCH] dial to select another melody track. You may also not select any Melody track.

The Time flashes to show current Tempo. If the METRONOME function is on, it flashes by the Tempo.

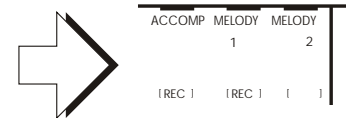
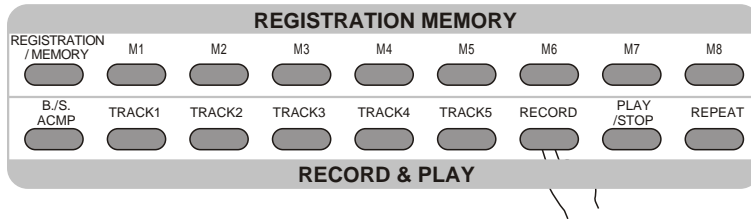

Notice:

If the former recorded Melody track is on (the relative icon shows in the screen), it could be monitored while recording. If you do not need the Melody sound, press the FUNCTION button to the Song Track position and use the CURSOR <> to select the Melody 1,2. Use the Tempo - to close it.

The volume of the melody is the current accompaniment volume.

After entering into the record standby, the keyboard will set the measure as 01. (It could not start from the pointed measure)

• 4. Recording

At this moment it records the left part of the keyboard you play. If you record both the Accompaniment and the melody, playing at the right part of the keyboard will start recording the melody.

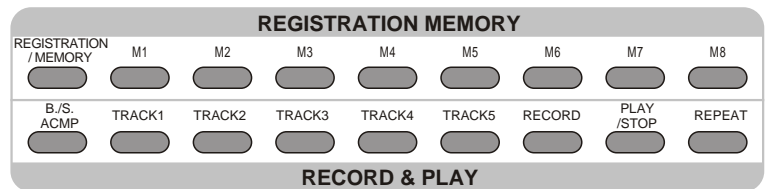
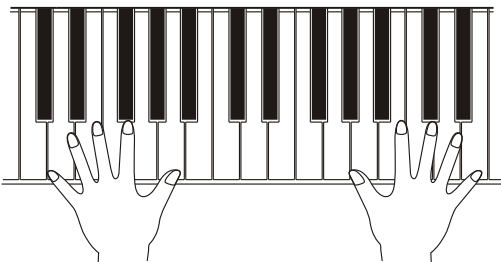

Also you can start recording by press the [START/STOP] button. At this moment there is only Rhythm. Only when you play the accompaniment chord come the Chord and Bass.

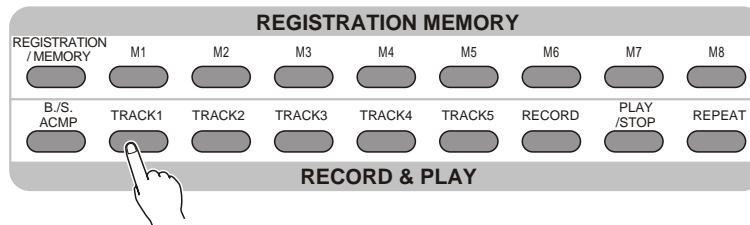

Play every section of the accompaniment(intro, main, etc). If you'd like to record both Accompaniment and Melody, playing at the right part of the keyboard will record the Melody.



Notice:

Song recording will delete all the former data of the same track.

Recording proceeds by measures. If you stop between the measure, the rest will be recorded as pause.

If the music Memory is full, the letter FULL will appear on the screen. The recording stops.

• 5. Stop Recording

You can stop recording by pressing the [PLAY/STOP] button either in the Song part or auto accompaniment part, or pressing the [ENDING] button.

If the record is stopped, there is no REC signal in the screen.

Voice number and volume of the accompaniment show in the screen.

Accompaniment & Melody Tracks Playback

• 1. Selecting S. NUMBER

If needed, press the FUNCTION button to select the Song Number. Then use the [SEARCH] dial to select No. 5 (USER SONG)

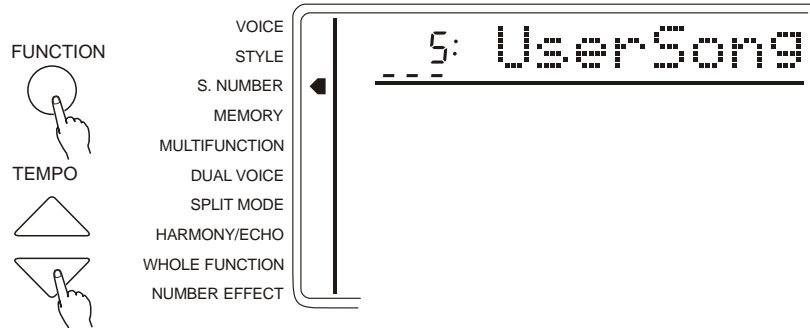

• 2. Start Playback

Press the [START/STOP] button, and you could open/close the accompaniment & melody tracks according to your need.

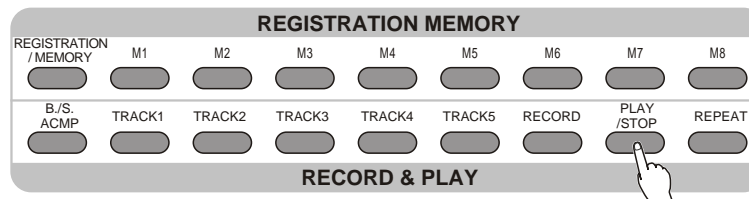

• 3. Stop Playback

The playback automatically stops at the end. You can also press the [START/STOP] button to stop the playback.

Notice:

Press the FUNCTION button to Song Track position, and use the Cursor ◀▶ buttons to select a certain track, and then use the CURSOR ◀▶ buttons or data roller to open/close this track. When closed, the track mark disappears. When the playback is on, the voice volume can be rewritten.

• 4. Rewriting the Voice & Volume

While playing, you could rewrite the setting of the voice of any track. After selecting a Voice number of one track (the mark flashes) by the Cursor buttons, use [SEARCH] dial to change the setting. The setting will soon work. The voice change in the record data will take in effect at the same time.

While playing, you could rewrite the setting of the volume of any track. After selecting a volume of one track (this mark flashes) by the Cursor buttons, use the [SEARCH] dial to change the setting. The setting will soon work. The volume change in the record data will take in effect at the same time.

Notice:

Only the Voice and Volume of the USER SONG can be rewritten.

PRACTICE FUNCTION

*. The keyboard provides two functions to help you practice.

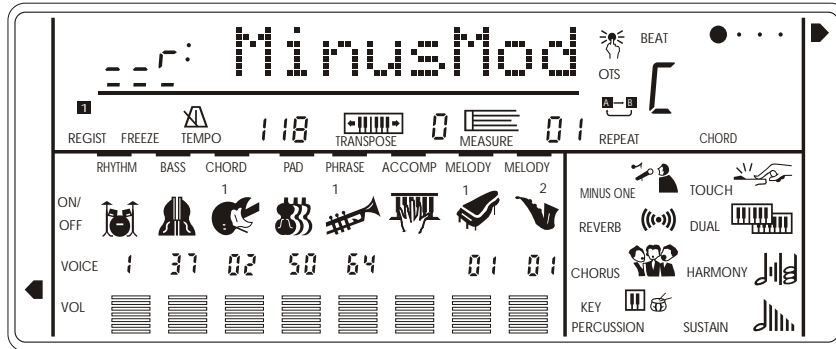

MINUS CHANNEL MODE

*. Under this mode, the left/right part of the keyboard of the DEMO could be closed. TO make you more convenient to follow the playing. “MinusMod” of the WHOLE FUNCTION has a parameter to control the Channel.

Press the MINUS CHANNEL button to open this function. The relative mark appears in the screen.

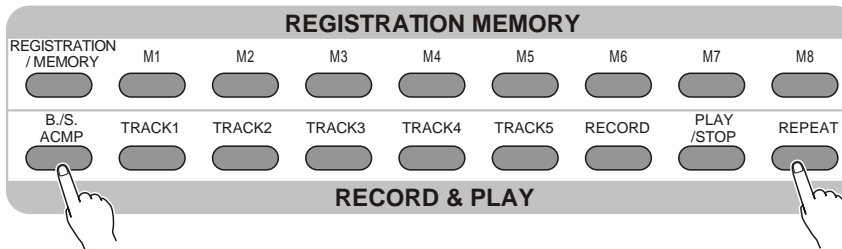

APPOINTING THE CHANNEL

Press the FUNCTION button to select WHOLE FUNCTION. (The “arrow” marks to the position). Then use the CURSOR button (▲▼) to select MinusMod parameter. Use the [SEARCH] dial to appoint the channel.

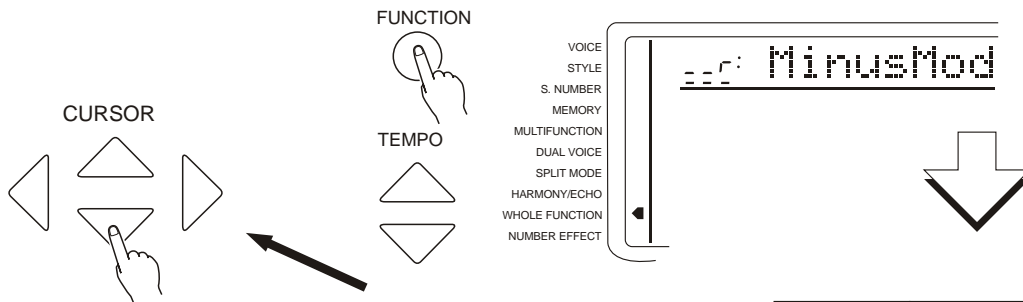

| Mode | Part Turned Off |
|------|---------------------|
| --r | Left hand MinusMod |
| L-- | Right hand MinusMod |
| L-r | Both hand MinusMod |

PRACTICE FUNCTION

*. The keyboard provides two functions to help you practice.

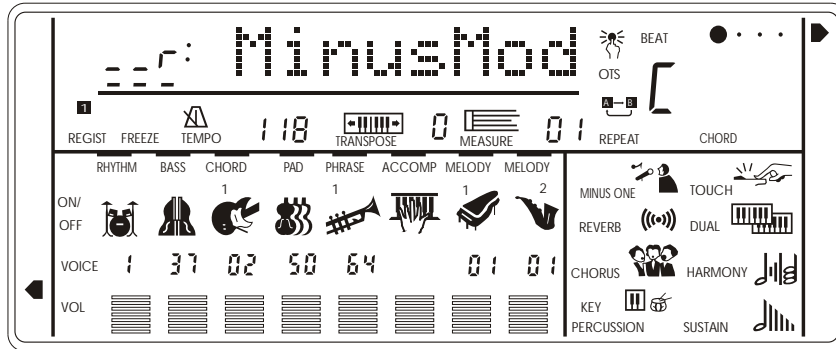

MINUS CHANNEL MODE

*. Under this mode, the left/right part of the keyboard of the DEMO could be closed. TO make you more convenient to follow the playing. “MinusMod” of the WHOLE FUNCTION has a parameter to control the Channel.

Press the MINUS CHANNEL button to open this function. The relative mark appears in the screen.

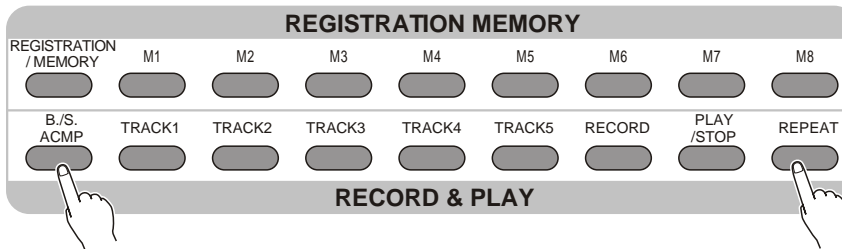

APPOINTING THE CHANNEL

Press the FUNCTION button to select WHOLE FUNCTION. (The “arrow” marks to the position). Then use the CURSOR button (▲▼) to select MinusMod parameter. Use the [SEARCH] dial to appoint the channel.

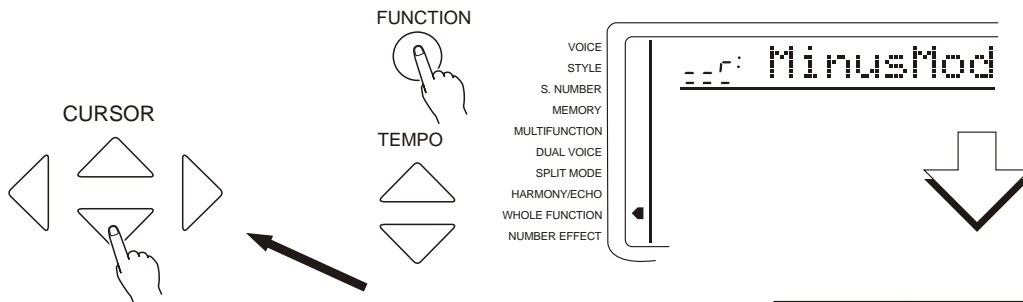

| Mode | Part Turned Off |
|------|---------------------|
| --r | Left hand MinusMod |
| L-- | Right hand MinusMod |
| L-r | Both hand MinusMod |

Notice:

Minus Channel Mode has no effect on the song you record by yourself.

Holding the MINUS CHANNEL button could quickly select the parameter of MinusMod.

When the power switch turns to ON, this keyboard will automatically select r(right hand MinusMod)

REPEATED PLAYBACK

*. This function lets you repeat a certain part of the song. During playback, press the [REPEAT] button at the beginning of your desired part(A shows in the screen) and press it again at its end(B shows in the screen). Then it can repeatedly play the part you desired until you press the [REPEAT] button again.

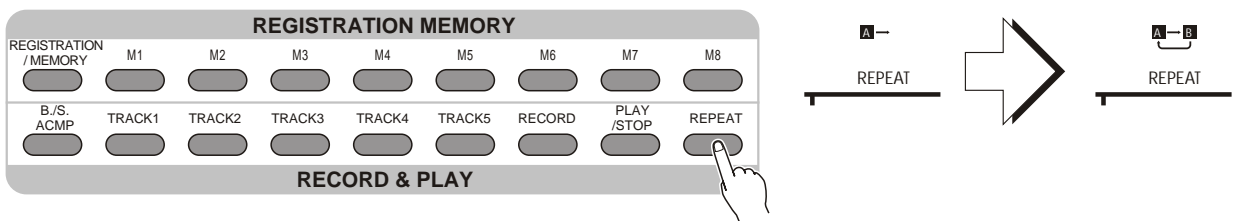

Also you can set the part you want to repeat even if the playback is off. Use measure parameter to set point A and then press the [REPEAT] button. Then set point B, and press [REPEAT] button again. Press the [START/STOP] button to start the playback of the part you desired.

Notice:

If you set the point A only, the repetition will start from A to the end.

For example, you set the point A at measure 2 and point B at measure 8, the repetition will play from measure 2 to 8.

WHOLE FUNCTION

Some of the operations in the WHOLE FUNCTION have been introduced before. But some have not. And we are going to introduce the new ones.

What displays in the screen are the abbreviations of the Functions. The following list their full names and their parameter extensions.

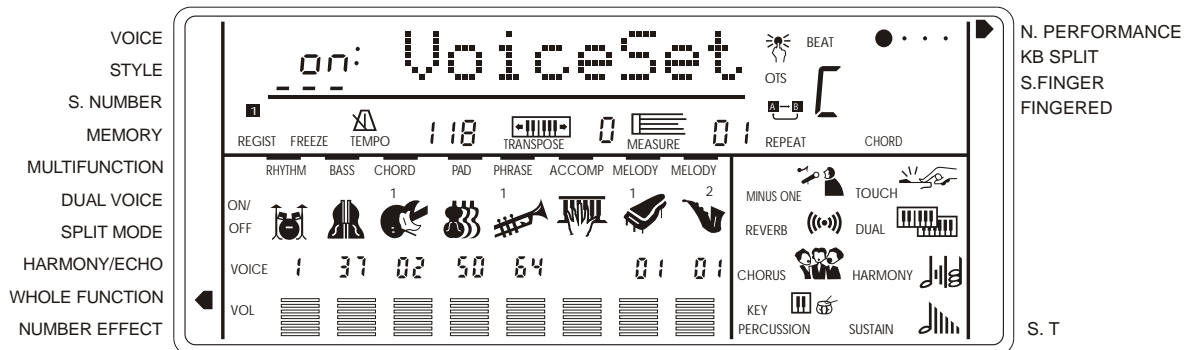

| Function | Display | extension | Page No |
|-------------------------|----------|-------------|---------|
| Keyboard volume | KybdVo1 | 00~127 | 47 |
| 8 Octave | Octave | -2~0~2 | 46 |
| Reverb Level | RevLevel | 00~127 | 46 |
| Chorus Level | ChoLevel | 00~127 | 47 |
| Pan | Pan | -7~0~7 | 47 |
| Voice set | VoiceSet | OFF, ON | 47 |
| Accompany volume | Acompvol | 00~127 | 47 |
| Accompany Separatepoint | AccSpPnt | 00~127 | 35 |
| Touch Sense | TouchSns | 00~127 | 48 |
| Minus mode | MinusMod | -r, L-, L-r | 43 |
| Minus channel right | MinusChR | 01~16 | 48 |
| Minus channel left | MinusChL | 01~16 | 48 |
| P B Range | PBRange | 01~12 | 22 |
| Metronome | Metronom | OFF, ON | 48 |
| Tuning | Tuning | -100~100 | 48 |
| Remote channel | RemoteCh | OFF, 01~16 | 49 |
| Keyboard output | KybdOut | OFF, ON | 49 |
| Keyboard Percussive | KBDPERC | 01~10 | 15 |
| 3D Effect | 3DEffect | OFF, ON | 26 |

Press the FUNCTION buttons to select the WHOLE FUNCTION (The “arrow” marks the position). Use the CURSOR (▲▼) buttons to select the parameter you need and then use [SEARCH] dial to set the parameter.

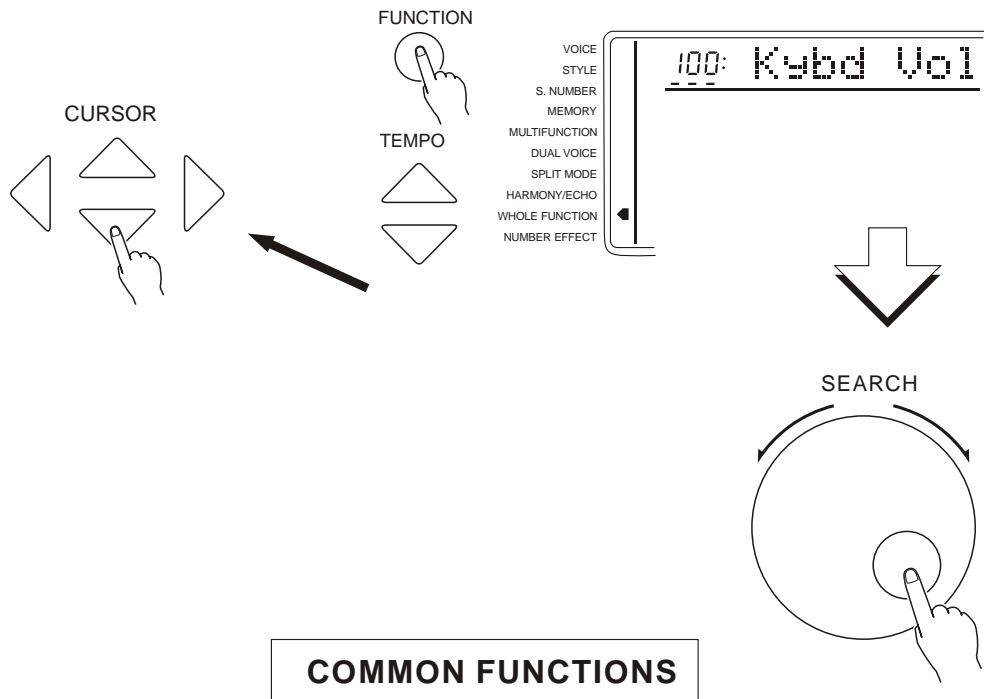

■ KEYBOARD VOLUME

To set the volume suitable to the accompaniment and playback. (including DUAL & SPLIT VOICE). Extension: 00 to 127. 00 stands for no sound, and 127 the highest Vol.

| | 100: Kybd Vol

Notice:

Holding the [VOICE] button can quickly select this function.

Press both CURSOR (◀▶) buttons to return to the original volume setting (100).

■ 8 OCTAVE

To change the Octave pitch of the voice in the right part of the keyboard. -1 is to fall by an Octave, and -2 by Octaves, and +1, +2 to rise by one or two Octaves.

| | 0: Octave

Notice:

Press both CURSOR (◀▶) buttons to return to the original volume setting (0).

■ REV LEVEL

To set the voice output to the REV LEVEL. Extension: 00-127. Return LEVEL is set by “SET RETURN REV LEVEL” above.

| | 28: RevLevel

Notice:

Press both CURSOR (◀▶) buttons to return to the original volume setting (28).

■ CHORUS LEVEL

Setting tone output to the CHORUS LEVEL. Extension: 00-127. Return chorus level is set by “SET RETURNCHOLEVEL” above.

```
| | 70: ChoLevel
```

Notice:

Press both CURSOR ◀▶ buttons to return to the original setting of Return CHOLEVEL (20).

■ PAN

To change voice stereo phase of the right part of the keyboard by the Voice function. Extension: -7(left) to +7(right)

```
| | 0: Pan
```

Notice:

*When the Voice Set is on, the PAN you select by VOICE is 0.
Holding Tempo -] and NUMBER button to input minus number.
Press both CURSOR ◀▶ buttons to return to the original setting.*

■ VOICE SET

This function automatically sets the parameters which have great influence on voice, in order to create the best effect..

The following are the types of different parameters.

- *. Octave
- *. REV LEVEL
- *. CHO LEVEL
- *. KBD VOL

```
| | on: VoiceSet
```

■ ACCOMPANIMENT VOLUME

To set suitable volume for Melody and Playback. Extension: 00-127. 00 stands for no sound and 127 the highest volume.

```
| | 100: AcompVol
```

Notice:

*Hold the [STYLE] button to quickly select this function.
Press both CURSOR ◀▶ buttons to return to the original volume setting(100).*

■ TOUCH SENSITIVITY

When the Touch Response function is on, this parameter determines the touch sense. The bigger the number, the higher the sense.

| | 100: TouchSns

Notice:

Press both CURSOR ◀▶ buttons to return to the original volume setting(100). Holding down the [TOUCH] button can quickly select this function.

■ MINUS CHANNEL.

You can make the Song(DEMO)Minus counterpoint to the passage. By closing the passage you can close the Minus during you practice.

| | 01: MinusChR

| | 02: MinusChL

Notice:

Passage 1-16 is available. Press both CURSOR ◀▶ buttons to return to the original number setting(01 for right hand, 02 for left hand).

■ METRONOME

You can open/close this function. When it is open, Metronome sounds with the function under accompany/Usersong and recording.

| | oFF: Metronom

Notice:

When the power switch turns on, this function is closed.

■ PITCH

Adjusting the Pitch a little bit to fit other musical instruments. Extension is from -100 to100. 00 is the standard Pitch.

Notice:

Press both CURSOR ◀▶ buttons to return to the original setting (00).

MIDI FUNCTIONS

MIDI FUNCTION

MIDI is an international standard. It connects musical instruments that have this function in order to control and transmit data to each other. Thus, it makes all the instrument a big system and greatly enlarge the whole function.

■ MIDI INTERFACE

MIDI IN receives the data from the outside devices to control this keyboard.

MIDI OUT transmits the data from this keyboard (note of the keyboard and Touch data)

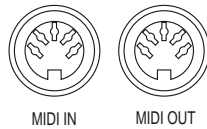

Notice:

MIDI connection cable should be no longer than 15m. Otherwise, wrong data and noise may occur.

■ REMOTE PASSAGE

To set the MIDI passage from which outside keyboard data is sent, you could select 01-16. The outside keyboard must settled the passage from which data is sent. Its MIDI OUT connects this keyboard's MIDI IN by MIDI cable. When the set is OFF, this keyboard will receive from all 16 passages. Press both Tempo + & - buttons to return to the original setting (OFF)

OFF: RemoteCh

■ KEYBOARD OUTPUT

To determine whether the data output from the MIDI OUT.

OFF: RemoteCh

APPENDIX

VOICE LIST

This instrument has 64-note maximum polyphony. This means that it can play a maximum of up to 64 notes at once, regardless of what functions are used. Auto Accompaniment uses a number of the available notes, so when Auto Accompaniment is used the total number of available notes for playing on the keyboard is correspondingly reduced. The same applies to the Split Voice and Song functions.

Caution: The Voice List includes MIDI program change numbers for each voice. Use these program change numbers when playing this instrument via MIDI from an external device.

| Voice No | MIDI No | Name of Voice | | Voice No | MIDI NO | Name of Voice | |
|----------------------|---------|-------------------------|---|-----------|---------|--------------------|---|
| PIANO | | | | STRINGS | | | |
| 01 | 0 | ACOUSTIC GRAND PIANO | | 41 | 40 | VIOLIN | |
| 02 | 1 | BRIGHT ACOUSTIC PIANO | | 42 | 41 | VIOLA | |
| 03 | 2 | ELECTRIC GRAND PIANO | | 43 | 42 | CELLO | |
| 04 | 3 | HONKY-TONK PIANO | | 44 | 43 | CONTRABASS | |
| 05 | 4 | ELECTRIC PIANO1 | 1 | 45 | 44 | TREMOLO ATRINGS | |
| 06 | 5 | ELECTRIC PIANO2 | 2 | 46 | 45 | PIZZICATO STRINGS | |
| 07 | 6 | HARPSICHORD | | 47 | 46 | ORCHESTRAL HARP | |
| 08 | 7 | CLAV1 | | 48 | 47 | TIMPANI | |
| CHROMATIC PERCUSSION | | | | RNSSEMBLE | | | |
| 09 | 8 | CELESTA | | 49 | 48 | STRINGS ENSEMBLE1 | 1 |
| 10 | 9 | GLOCKENSPIEL | | 50 | 49 | STRINGS ENSEMBLE12 | 2 |
| 11 | 10 | MUSIC BOX | | 51 | 50 | SYNTH STRINGS1 | 1 |
| 12 | 11 | VIBRAPHONE | | 52 | 51 | SYNTH STRINGS2 | 2 |
| 13 | 12 | MARINBA | | 53 | 52 | CHOIR AAHS | |
| 14 | 13 | XYLOPHONE | | 54 | 53 | VOICE OOHS | |
| 15 | 14 | TUBULAR BELLS | | 55 | 54 | SYNTH VOICE | |
| 16 | 15 | DULCIMER | | 56 | 55 | ORCHESTRA HIT | |
| ORGAN | | | | BRASS | | | |
| 17 | 16 | DRAWBAR ORGAN | | 57 | 56 | TRUMPET | |
| 18 | 17 | PERCUSSIVE ORGAN | | 58 | 57 | TROMBONE | |
| 19 | 18 | ROCK ORGAN | | 59 | 58 | TUBA | |
| 20 | 19 | CHURCH ORGAN | | 60 | 59 | MUTED TRUMPET | |
| 21 | 20 | FEED ORGAN | | 61 | 60 | FRENCH HORN | |
| 22 | 21 | ACCORDION | | 62 | 61 | BRASS SECTION | |
| 23 | 22 | HARMONICA | | 63 | 62 | SYNTH BRASS1 | 1 |
| 24 | 23 | TANGO ACCORDION | | 64 | 63 | SYNTH BRASS2 | 2 |
| GUITAR | | | | REED | | | |
| 25 | 24 | ACOUSTIC GUITAR(NYLIN) | | 65 | 64 | SOPRANO SAX | |
| 26 | 25 | ACOUSTIC GUITAR(STEEL) | | 66 | 65 | ALTO SAX | |
| 27 | 26 | ELECTRNIC GUITAR(JAZZ) | | 67 | 66 | TENOR SAX | |
| 28 | 27 | ELECTRNIC GUITAR(CLEAN) | | 68 | 67 | BARTION SAX | |
| 29 | 28 | ELECTRNIC GUITAR(MUTED) | | 69 | 68 | OBOE | |
| 30 | 29 | OVERDRIVEN GUITAR | | 70 | 69 | ENGLISH HORN | |
| 31 | 30 | DISTOTION GUITAR | | 71 | 70 | BASSOON | |
| 32 | 31 | GUITAR HARMONICS | | 72 | 71 | CLARINET | |
| BASS | | | | PIPE | | | |
| 33 | 32 | ACOUSTIC BASS | | 73 | 72 | PICCOLO | |
| 34 | 33 | ELECTRIC BASS(FINGER) | | 74 | 73 | FLUTE | |
| 35 | 34 | ELECTRIC BASS(PICK) | | 75 | 74 | RECORDER | |
| 36 | 35 | FRETLESS BASS | | 76 | 75 | PAN FLUTE | |
| 37 | 36 | SLAP BASS1 | 1 | 77 | 76 | BLOWN BOTTLE | |
| 38 | 37 | SLAP BASS2 | 2 | 78 | 77 | SHAKUHACHI | |
| 39 | 38 | SYNTH BASS1 | 1 | 79 | 78 | WHISTLE | |
| 40 | 39 | SYNTH BASS2 | 2 | 80 | 79 | OCARINA | |

VOICE LIST

| Voice No | MIDI No | Name of Voice | |
|----------------------|---------|------------------|--|
| SYNTH REED | | | |
| 81 | 80 | LEAD1(WOUIRE) | |
| 82 | 81 | LEAD2(SAWTIITH) | |
| 83 | 82 | LEAD3(CALLIOPE) | |
| 84 | 83 | LEAD4(CHIFF) | |
| 85 | 84 | LEAD5(CHARANG) | |
| 86 | 85 | LEAD6(VOICE) | |
| 87 | 86 | LEAD7(FIFTH) | |
| 88 | 87 | LEAD8(BASS+LEAD) | |
| SYNTH PAD | | | |
| 89 | 88 | PAD1(NEW AGE) | |
| 90 | 89 | PAD2(WARM) | |
| 91 | 90 | PAD3(POLYSYNTH) | |
| 92 | 91 | PAD4(CHOIR) | |
| 93 | 92 | PAD5(BOWED) | |
| 94 | 93 | PAD6(METALLIC) | |
| 95 | 94 | PAD7(HALO) | |
| 96 | 95 | PAD8(SWEEP) | |
| SYNTH EFFECTS | | | |
| 97 | 96 | FX1(RAIN) | |
| 98 | 97 | FX2(SOUNDTRACK) | |
| 99 | 98 | FX3(CRYSTAL) | |
| 100 | 99 | FX4(ATMOSPHERE) | |
| 101 | 100 | FX5(BRIGHTNESS) | |
| 102 | 101 | FX6(GOBLINS) | |
| 103 | 102 | FX7(ECHOES) | |
| 104 | 103 | FX8(SCO-FI) | |
| ETHNIC 民族乐器 | | | |
| 105 | 104 | SITAR | |
| 106 | 105 | BANJO | |
| 107 | 106 | SHAMISEN | |
| 108 | 107 | GUZHENG | |
| 109 | 108 | KALIMBA | |
| 110 | 109 | BAGPIPE | |
| 111 | 110 | ERHU | |
| 112 | 111 | SUONAI | |
| PERCUSSION | | | |
| 113 | 112 | TINKLE BELL | |
| 114 | 113 | AGOGO | |
| 115 | 114 | STEEL DRUMS | |
| 116 | 115 | WOOOBLOCK | |
| 117 | 116 | TAIKO DRUM | |
| 118 | 117 | MELODIC TOM | |
| 119 | 118 | SYNTH DRUM | |
| 120 | 119 | REVERSE CYMBAL | |

| Voice No | MIDI No | Name of Voice | |
|---------------------|---------|--------------------|------|
| SOUND EFFECT | | | |
| 121 | 120 | FRET NOSE | |
| 122 | 121 | BREATH NOISE | |
| 123 | 122 | SEASHORE | |
| 124 | 123 | BIRD TWEET | |
| 125 | 124 | TELEPHONE RING | |
| 126 | 125 | HELICOPTER | |
| 127 | 126 | APPLAUSE | |
| 128 | 127 | GUNSHOT | |
| FOLK | | | |
| 129 | 128 | YUNLUO | |
| 130 | 129 | GUANMEILANG | |
| 131 | 130 | BIANMANG | |
| 132 | 131 | YANGQIN | |
| 133 | 132 | LUSHENG | |
| 134 | 133 | PIBA | |
| 135 | 134 | LUOQIN | |
| 136 | 135 | YUQIN | |
| 137 | 136 | DARUAN | |
| 138 | 137 | ZHONGRUAN | |
| 139 | 138 | GUOHU | |
| 140 | 139 | ERHU | |
| 141 | 140 | ZHONGHU | |
| 142 | 141 | ERHUQUN1 | 1 |
| 143 | 142 | ERHUQUN2 | 2 |
| 144 | 143 | ZHONGHUQUN | |
| 145 | 144 | BANGDI | |
| 146 | 145 | KUNDI | |
| 147 | 146 | XIAO | |
| 148 | 147 | BANHU | |
| 149 | 148 | XIPI | |
| 150 | 149 | ZHUIHU | |
| 151 | 150 | SANXIAN | |
| 152 | 151 | GUZHENG | |
| 153 | 152 | GUOYINSUONA | |
| PERCUSSION | | | |
| 154 | 153 | STANDARD DRUMS | |
| 155 | 154 | CHINESE PERCUSSION | |
| 156 | 155 | ROOM DRUMS | |
| 157 | 156 | ROCK DRUMS | |
| 158 | 157 | ELECTRIC DRUMS | |
| 159 | 158 | T 808 DRUMS | T808 |
| 160 | 159 | JAZZ DRUMS | |
| 161 | 160 | BRUSH KIT | |
| 162 | 161 | CLASSIC DRUMS | |
| 163 | 162 | SFX KIT | |

RHYTHM LIST

| No | Name | |
|---------------|--------------|------|
| 8/16BEAT 8/16 | | |
| 00 | 8BEAT-1 | 8 1 |
| 01 | 8BEAT-2 | 8 2 |
| 02 | 8BEAT-3 | 8 3 |
| 03 | 16BEAT-1 | 16 1 |
| 04 | 16BEAT-2 | 16 2 |
| 05 | 16BEAT-3 | 16 3 |
| POP | | |
| 06 | POOPROCK | |
| 07 | FOLKROCK | |
| 08 | POPBOLERO | |
| 09 | POPWALTZ | |
| 10 | SOULBALLAD | |
| 11 | MOOTOWN | |
| DANCE | | |
| 12 | HOUSE | |
| 13 | TECHNO-1 | 1 |
| 14 | TECHNO-2 | 2 |
| 15 | RAVE | |
| 16 | DANCE-1 | 1 |
| 17 | DANCE-2 | 2 |
| 18 | DISCO-70S | 70 |
| 19 | DISCO | |
| 20 | MACARENA | |
| R&B | | |
| 21 | GOSPEL-1 | 1 |
| 22 | GOSPEL-2 | 2 |
| 23 | R&B-1 | 1 |
| 24 | R&B-2 | 2 |
| 25 | BLUES-1 | 1 |
| 26 | BLUES-2 | 2 |
| 27 | FUNK | |
| ROCK | | |
| 28 | ROCK-60S | 60 |
| 29 | ROCK-70S | 70 |
| 30 | ROCK-80S | 80 |
| 31 | BALLROCK | |
| 32 | SLOWROCK | |
| 33 | SLOWROCK6/8 | 6/8 |
| ROCK&ROLL | | |
| 34 | ROCK&ROLL-1 | 1 |
| 35 | ROCK&ROLL-2 | 2 |
| 36 | SHUFFLE | |
| 37 | TWIST | |
| 38 | BOOGIE-1 | 1 |
| 39 | BOOGIE-2 | 2 |
| SWING/JA / | | |
| 40 | SWING | |
| 41 | LOUNGE | |
| 42 | DIXIE-1 | 1 |
| 43 | DIXIE-2 | 2 |
| 44 | JAZZBALLAD-1 | 1 |
| 45 | JAZZBALLAD-2 | 2 |
| 46 | JAZZWALTZ | |
| 47 | CHARLSTON | |
| 48 | RAGTIME | |
| COUNTRY | | |

| NO | Name | |
|-------------|--------------|-----|
| 49 | COUNTRY-1 | 1 |
| 50 | COUNTRY-2 | 2 |
| 51 | COUNTRYDANCE | |
| 52 | COUNTRYROCK | |
| 53 | COUNTRYWALTZ | |
| CARIBBEAN | | |
| 54 | REGGAE-1 | 1 |
| 55 | REGGAE-2 | 2 |
| 56 | CARIBBEAN | |
| LATIN-1 1 | | |
| 57 | BOSSA-1 | 1 |
| 58 | BOSSA-2 | 2 |
| 59 | SAMBA-1 | 1 |
| 60 | SAMBA-2 | 2 |
| 61 | RUMBA | |
| 62 | BEGUINE | |
| 63 | CHACHA-1 | 1 |
| 64 | CHACHA-2 | 2 |
| LATIN-2 2 | | |
| 65 | SALSA | |
| 66 | CUMBIA | |
| 67 | MERENQUE | |
| 68 | MAMBO | |
| 69 | LATIN | |
| 70 | GIPSY | |
| 71 | D.SAMBA | |
| ORIENTAL | | |
| 72 | CINGENE | |
| 73 | MUS5/8 | |
| 74 | ORIENTAL | |
| 75 | OYUNHAVA | |
| WORLD MUSIC | | |
| 76 | SEVILLIANA | |
| 77 | HOLLYWOOD | |
| 78 | SP.RUMBA | |
| 79 | SP.BOLERO | |
| 80 | SIRTAKI | |
| 81 | BAROQUE | |
| 82 | HAWAII | |
| BALLROOM | | |
| 83 | FOXTROT | |
| 84 | QUICKSTEP | |
| 85 | SLOWFOX | |
| 86 | TRAD.WALTZ | |
| 87 | JIVE | |
| 88 | PASODOBLE | |
| 89 | TANGO | |
| 90 | TANGOARG | |
| WALTZ/MARCH | | |
| 91 | GERMWALTZ | |
| 92 | VIENNAWALTZ | |
| 93 | MUSETTE | |
| 94 | SLOWWALTZ | |
| 95 | MARCH | |
| 96 | MARCH6/8 | 6/8 |
| 97 | POLKA | |
| 98 | D.POLKA | |
| 99 | SCHLAGER | |

DRUM SET TABLE (MIDI CHANNEL 10)

| | 6 HQ TR808 SET | 7 HQ DANCE SET | 8 BRUSH | 9 ORCHESTRA | 10 SFX SET |
|----------|-------------------|-------------------|-------------|-----------------|---------------------|
| 39 - D#2 | | | | Closed Hi Hat | * |
| 40 - E2 | | | | Pedal Hi-Hat | * |
| 41 - F2 | | | | Open Hi Hat | * |
| 42 - F#2 | | | | Ride Cymbal | * |
| 43 - G2 | | | | | * |
| 44 - G#2 | | | | | * |
| 45 - A2 | | | | | * |
| 46 - A#2 | | | | | * |
| 47 - B2 | HQ 909 BD | HQ Dance Kick | Jazz BD2 | Concert BD 2 | * |
| 48 - C3 | HQ 808 BD | HQ Elec Kick2 | Jazz BD1 | Concert BD 1 | * |
| 49 - C#3 | 808 Rim shot | | | | * |
| 50 - D3 | 808 Snare Drum | HQ Dance snare1 | Brush Tap | Concert SD | * |
| 51 - D#3 | | | Brush Slap | Castanets | High Q |
| 52 - E3 | HQ 909 Snare | HQ Dance snare2 | Brush Swirl | Concert SD | Slap |
| 53 - F3 | 808 Low Tom2 | Elec Low Tom2 | | Timpani F | Scratch Push |
| 54 - F#3 | 808 CHH [EXC1] | 808 CHH [EXC1] | | Timpani F# | Scratch Pull |
| 55 - G3 | 808 Low Tom2 | Elec Low Tom1 | | Timpani G | Sticks |
| 56 - G#3 | 808 CHH [EXC1] | 808 CHH [EXC1] | | Timpani G# | Square Click |
| 57 - A3 | 808 Mid Tom2 | Elec Mid Tom2 | | Timpani A | Metronome Click |
| 58 - A#3 | 808 OHH [EXC1] | 808 OHH [EXC1] | | Timpani A# | Metronome Bell |
| 59 - B3 | 808 Mid Tom1 | Elec Mid Tom1 | | Timpani B | Guitar Slide |
| 60 - C4 | 808 Hi Tom2 | Elec Hi Tom2 | | Timpani c | Gt Cut Noise (down) |
| 61 - C#4 | 808 Cymbal | | | Timpani c# | Gt Cut Noise (up) |
| 62 - D4 | 808 HiTom1 | Elec Hi Tom1 | | Timpani d | Double Bass Slap |
| 63 - D#4 | | | | Timpani d# | Key Click |
| 64 - E4 | | Reverse Cymbal | | Timpani e | Laughing |
| 65 - F4 | | | | Timpani f | Screaming |
| 66 - F#4 | | | | | Punch |
| 67 - G4 | | | | | Heart Beat |
| 68 - G#4 | 808 Cowbell | | | | Footsteps1 |
| 69 - A4 | | | | Concert Cymbal2 | Footsteps2 |
| 70 - A#4 | | | | | Applause |
| 71 - B4 | | | | Concert Cymbal1 | Door Creaking |
| 72 - C5 | | | | | Door Closing |
| 73 - C#5 | | | | | Scratch |
| 74 - D5 | 808 High Conga | | | | Wind Chime |
| 75 - D#5 | 808 Mid Conga | | | | Car Engine Start |
| 76 - E5 | 808 Low Conga | | | | Car Breaking |
| 77 - F5 | | | | | Car Pass |
| 78 - F#5 | | | | | Car Crash |
| 79 - G5 | | | | | Police Siren |
| 80 - G#5 | | | | | Train |
| 81 - A5 | | | | | Jet Take-off |
| 82 - A#5 | 808 Maracas | | | | Helicopter |
| 83 - B5 | | | | | Starship |
| 84 - C6 | | | | | Gun Shot |
| 85 - C#6 | | | | | Machinegun |
| 86 - D6 | | | | | Lasergun |
| 87 - D#6 | 808 Claves | | | | Explosion |
| 88 - E6 | | | | | Dog |
| 89 - F6 | | | | | Horse Gallop |
| 90 - F#6 | | | | | Birds |
| 91 - G6 | | | | | Rain |
| 92 - G#6 | | | | | Thunder |
| 93 - A6 | | | | | Wind |
| 94 - A#6 | | | | | Sea Shore |
| 95 - B6 | | | | | Stream |
| 96 - C7 | | | | | Bubble |
| | | | | | * |
| | | | | | * |
| | | | | | * |
| | | | | | * |

Technical Specification

Keyboard:

- 88 -Key keyboard with hammer action

Voice:

- 348 PCM voice
- the maximum coinstantaneous voice:64
- the keyboard percussive:1~9 group
- sound effect:1 group
- volume:00~127
- octachord:-2~2
- phasic:-7~7
- keyboard split: left hand and right hand voice
- dual voice right hand voice 1;right hand vioce2
- harmony and resonance:10 styles
- DSP reverb styles:8 styles
- DSP chorus styles:8 styles
- The DSP reverb and chorus sending level:00~127
- The DSP reverb and chorus return level:00~127

Auto Accompaniment Function

- 100 rhythms
- accompaniment track: rhythm , Bass, rhythmic chord , long chord, sentence1/2,
- large/small accompaniment mode
- accompaniment track setting : ON/OFF,voice, volume
- accompaniment control: synchro, intro, Main A/B (Auto Fill-ins) ending , start/stop
- tempo: 40~240
- accompaniment volum:00~127
- accompaniment split

Songs:

- 4 Demo songs and 1 User song.

Record track:

- 3 record tracks

Accompaniment mode:

- Normal Play, Keyboard Split, Single Finger, Fingered

Panel Parameter Memory Bank:

- 8 Banks, Accompaniment Freeze

Total Function

- Transpose: -12~+12
- Metronome: ON/OFF

Display:

- 122×50mm large LCD screen with orange back-light.

Control Buttons:

- Up/ Down/Right/ Left Cursors, Up/Down Function buttons, Mode button, Numeric buttons:0~9, ▲▼Cursor buttons

● MIDI function:

Receive and Send

Auxiliary Interfaces

- DC input, earphone/auxiliary output, foot switch
- MIDI IN & OUT

Power output:

- 45W+45W
- earphone/auxiliary output: the resistance output:32 Ω
- loudspeaker
- 16.5cm×2+5cm×2 the resistance output 4 Ω

Voltage:

- 220V DC

Dimension:

- 138 (Length)×53 (Height)×85 (Width)cm

Weight:

- 70 kg

Included accessories:

- Screws, Screw Caps
- Power Supply Cable
- owner's manual
- repairing card

* The specifications may change later.

WELCOME...

To the happy family of satisfied PRELUDE electronic musical instrument owners! To get the most out of the many features and functions of the keyboard, please be sure to read carefully this manual and keep it at hand for future reference.

MAIN FEATURES

- Strong multifunctional LCD system with large-screen display, which makes selecting and editing parameters much easier.
- 153 different kinds of voices, including 4 voices of Chinese folk instruments(Trichord, Gu-Zheng, Erhu, Suona)
- Almost including 100 popular accompaniment styles in the world. Each rhythm has its own intro and main (A, B two types), variation and ending.
- 32 types of commonly-used voices and 32 types of commonly-used styles for rapid choice.
- With 9 groups of percussion instrument and a special-effect-voice group, including a group of Chinese traditional percussion instrument.
- Song Recording function can record one accompaniment track and two melody tracks.
- Soft LCD back light makes the piano more luxurious.
- Be able to synthesize certain digital effects like the reverb、 chorus、 and 3 D stereo effect, which could create various sound field effects.
- Be able to record one user song..
- Beautiful demo songs, making great contributions to lifting your performance level.
- Memory Bank can reserve at most 8 panel parameter settings and each setting can be recalled whenever you want.
- Minus Channel Mode and Repeated Playback function are excellent for teaching and practising.
- MIDI function makes his instrument able to connect to any other standard MIDI system.